

**MCZ**

**STAR-EGO-SUITE-CLUB-MUSA \_ mod.HYDRO**

**EN**

# USE AND MAINTENANCE MANUAL

PART 2 - OPERATION AND CLEANING

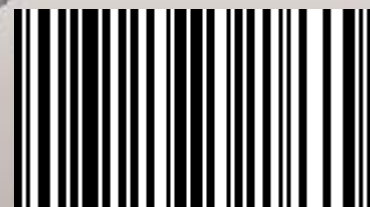

8901505800

<b>4. OPERATION .....</b>	<b>4</b>
4.1. PRE-LIGHTING WARNINGS.....	4
4.2. PRE-LIGHTING CHECK .....	5
4.3. LOADING THE PELLETS.....	5
4.4. SUPPLEMENTARY HOPPER CONDUIT (accessory) .....	5
4.5. SAFETY .....	5
4.6. User Training.....	6
4.7. DISPLAY PANEL AND COMMANDS.....	7
4.7.1. Control panel logic .....	7
4.8. SETTINGS TO CARRY OUT BEFORE FIRST LIGHTING.....	9
4.8.1. Setting current day and time.....	9
4.8.2. Setting the language .....	10
4.8.3. Procedure for recipe selection .....	11
4.9. CONTROL OF WATER TEMPERATURE IN BOILER.....	11
4.10. FIRST LIGHTING .....	12
4.10.1. Start-up/shutdown from the control panel .....	12
4.10.2. Note on first ignition .....	12
4.11. OPERATING MODE .....	13
4.11.1. Operating concept .....	13
4.11.2. Automatic mode .....	13
4.11.2.1. <i>Room sensor</i> .....	13
4.11.2.2. <i>Connecting an external room thermostat (3) or storage tank (3)</i> .....	14
4.11.3. Automatic mode with AUTO-ECO .....	15
4.11.3.1. <i>Activation /de-activation of AUTO-ECO mode</i> .....	16
4.12. HOT AIR VENTILATION SUITE-CLUB-MUSA 22 KW .....	17
4.13. SLEEP FUNCTION .....	18
4.14. TIMER .....	18
4.14.1. Current date and clock .....	18
4.14.2. TIMER activation and selection of a programme. ....	19
4.14.3. TIMER de-activation.....	20
4.15. PRE-SET WEEKLY AND DAILY PROGRAMMES .....	20
4.15.1. Weekly programmes .....	20
4.15.2. Daily programmes.....	22
4.16. PRACTICAL EXAMPLE OF DAILY PROGRAMMING .....	23
4.16.1. Setting of a daily programme .....	23
4.17. SAFETY DEVICES.....	24
4.18. ALARM SIGNALLING .....	25
4.19. Exiting alarm condition .....	27
4.19.1. Shutdown of the stove .....	27
<b>5. RECOMMENDATIONS FOR A SAFE USE.....</b>	<b>29</b>
<b>6. MAINTENANCE AND CLEANING.....</b>	<b>31</b>
6.1. DAILY OR WEEKLY CLEANING PERFORMED BY THE USER .....	31
6.1.1. Brazier cleaning .....	31
6.1.2. Ash tray cleaning .....	31
6.1.3. Clean the exchanger and the undergrate space every 2/3 days. ....	32
6.1.4. Cleaning the glass.....	33
6.1.5. Cleaning of the air filter .....	33
6.1.6. Cleaning of stainless steel and satin-finish surfaces .....	33
6.1.7. Cleaning of painted parts.....	33
6.2. CLEANING TO BE PERFORMED BY SPECIALIZED TECHNICIAN .....	34
6.2.1. Cleaning the heat exchanger and the pipe unit .....	34
6.2.1.1. <i>CLEANING THE EXCHANGER AND PIPE UNIT (EGO/STAR)</i> .....	34
6.2.1.2. <i>CLEANING THE EXCHANGER AND PIPE UNIT (SUITE/MUSA and CLUB):</i> .....	35
6.2.2. REPLACEMENT OF OVERPRESSURE SILICON DAMPER FOR COMBUSTION CHAMBER.....	36
6.2.3. Shutting the stove down (end of season).....	37
6.3. CHECK OF INTERNAL COMPONENTS.....	37

<b>7. PROBLEMS / CAUSES / SOLUTIONS.....</b>	<b>39</b>
<b>8. ELECTRICAL DIAGRAMS .....</b>	<b>41</b>
8.1. HEATING-ONLY VERSION.....	41
8.2. VERSION THAT PRODUCES DHW.....	42

## 4. OPERATION

### 4.1. PRE-LIGHTING WARNINGS



**Do not touch the stove during the first lighting, as it is during this phase that the paint sets. If you touch the paint, you may expose the steel surface.**

If necessary, touch up the paint with the aerosol spray in the original colour (see the section "Accessories for pellet stoves").



**It is good practice to provide plenty of ventilation in the room during the initial lighting, as the stove will give off a small amount of smoke and smell of paint.**



**ATTENTION!**

**Please ensure the brazier is clear of ALL pellets and ash build up following any failed ignitions. Failure to clear out the brazier prior to resetting may result in further failed ignitions or in certain conditions an explosive ignition.**

Do not stay near the stove, and as previously mentioned, ventilate the room. The smoke and the smell of paint will vanish after about one hour of operation. There are no health risks involved.

The stove will be subject to expansion and contraction during the stages of lighting and cooling down, and may therefore make slight creaking noises.

This phenomenon is absolutely normal, the structure being made of sheet steel, and must not be considered a fault.

It is extremely important to be sure not to take the stove to full heat straight away, but to bring it gradually up to temperature.



**Do not demand full heating performance straight away!**

Try to get familiar with the commands given from the control panel.



**ATTENTION!**

**If during operation or initial ignition you encounter smoke spillage in to the room from the appliance or the flue then please switch off the appliance, ventilate the room and contact the installation / service engineer immediately.**

## 4.2. PRE-LIGHTING CHECK

Check that all the safety conditions described above have been met.

Make sure you have read and completely understood the contents of this instruction booklet.

Remove any components which might burn from the firebox and from the glass (various instructions and adhesive labels).

Check that the grate **A** is properly positioned and rests correctly on the base.



After long periods of disuse, remove from the hopper (**using a vacuum cleaner with an extension**) any remains of pellets which have lain there for some time, since they may have absorbed moisture, which changes their original characteristics and makes them unsuitable for burning.

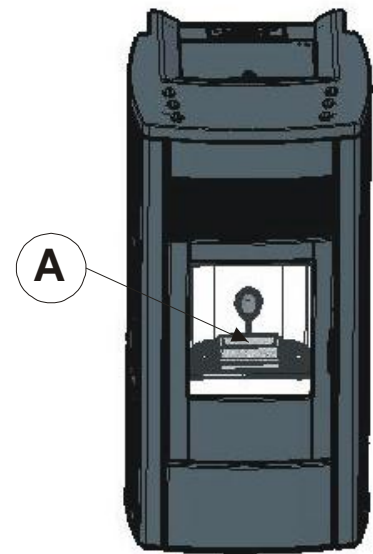

## 4.3. LOADING THE PELLETS

Fuel is loaded from the upper part of the stove by opening a door. Pour the pellets in the hopper. When empty, it will hold slightly more than a 15 kg sack.

This is easier if performed in two steps:

- Pour half of the contents into the hopper and wait for the fuel to settle on the bottom.
- Then pour in the rest



**Never remove the protection grille in the hopper. When filling, do not let the sack of pellets touch any hot surfaces.**

**Do not place any type of fuel in the hopper other than pellets that are compliant with the specifications provided previously.**



## 4.4. SUPPLEMENTARY HOPPER CONDUIT (accessory)

On the rear part of the stove, in correspondence of the pellet hopper, a pre-cut knockout panel has been provided for connecting a conduit for a supplementary hopper (accessory) externally of the stove. To open the pre-cut knockout panel, strike it with a rubber mallet.

Place the conduit plate on the stove body so that the conduit itself faces upward. Fasten the conduit to the stove body using the 4 screws provided with the accessory.

## 4.5. SAFETY

**PROCEDURE TO FOLLOW IF ANY SMOKE SPILLAGE IS SEEN WITHIN THE ROOM OR THE APPLIANCE SUFFERS FROM AN EXPLOSIVE IGNITION PLEASE TURN OFF THE APPLIANCE, VENTILATE THE ROOM AND CONTACT THE INSTALLER/SERVICE ENGINEER IMMEDIATELY.**

## 4.6. User Training

In ALL cases the installation and commissioning engineer MUST carry out a thorough handover of the appliance to the homeowner / end user. The following elements should be covered to the satisfaction of the end user. Failure to do this may result in unsafe use of the appliance:

- Explanation of the appliance and how it works
- Necessity to maintain ventilation to the appliance and the issues that may arise otherwise
- Fuel useage and supply
- How to light the appliance safely
- What to do in the event of failed ignitions
- What to do in the event of alarms (in particular those generated when the appliance runs out of fuel)
- How to maintain the appliance correctly and the importance of carrying out these tasks each month
- It is good practise to agree a date for the first annual service

- Explain the importance of the CO alarm in accordance with approved document J of the building regs
- Explain the need for the flue draft stabiliser and its position within the flue system

**ONLY FOR UK**

- Discuss the use of secondary heating systems if applicable
- Explain how the remote control or room stats operate and their optimal positioning

- Explain the need for the appliance data plate in accordance with approved document J of the building regulations
- The commissioning process and paperwork should also be explained to the homeowner. A copy of the base settings on the commissioning paperwork should also be left with the appliance.

**ONLY FOR UK**

## **4.7. DISPLAY PANEL AND COMMANDS**

### **4.7.1. Control panel logic**

Reported below are some useful information to understand the navigation logic and use the control panel:

- The luminosity of the control panel is switched off after about 30" seconds of the keyboard being inactive. To switch on the back lighting again just press any of the buttons on the panel.
- The first screen that appears displays the operating status of the stove (ON, OFF, LIGHTING, SHUTDOWN..) that alternates with any other settings activated (TIMER, SLEEP, AUTO ECO..)
- By pressing any of the 4 keys around the display (C D E F) you access the stove's operation settings screen (level of the flame, fan, set temperature, automatic mode..). From this level the 4 keys around the display assume "dedicated" functions, i.e. they directly refer to the corresponding words that appear in the 4 corners of the display (e.g.: the word in the top right hand corner refers to the D key).
- When a setting is modified in any menu level without confirming the modification using the "OK" key and leaving the keypad inactive for some seconds, the initial screen reappears and the modifications are not saved.
- If from any menu level the on/off (B) key is briefly pressed, the display is automatically taken back to the initial screen (stove operating status) without saving any modifications not confirmed with the "OK" key.

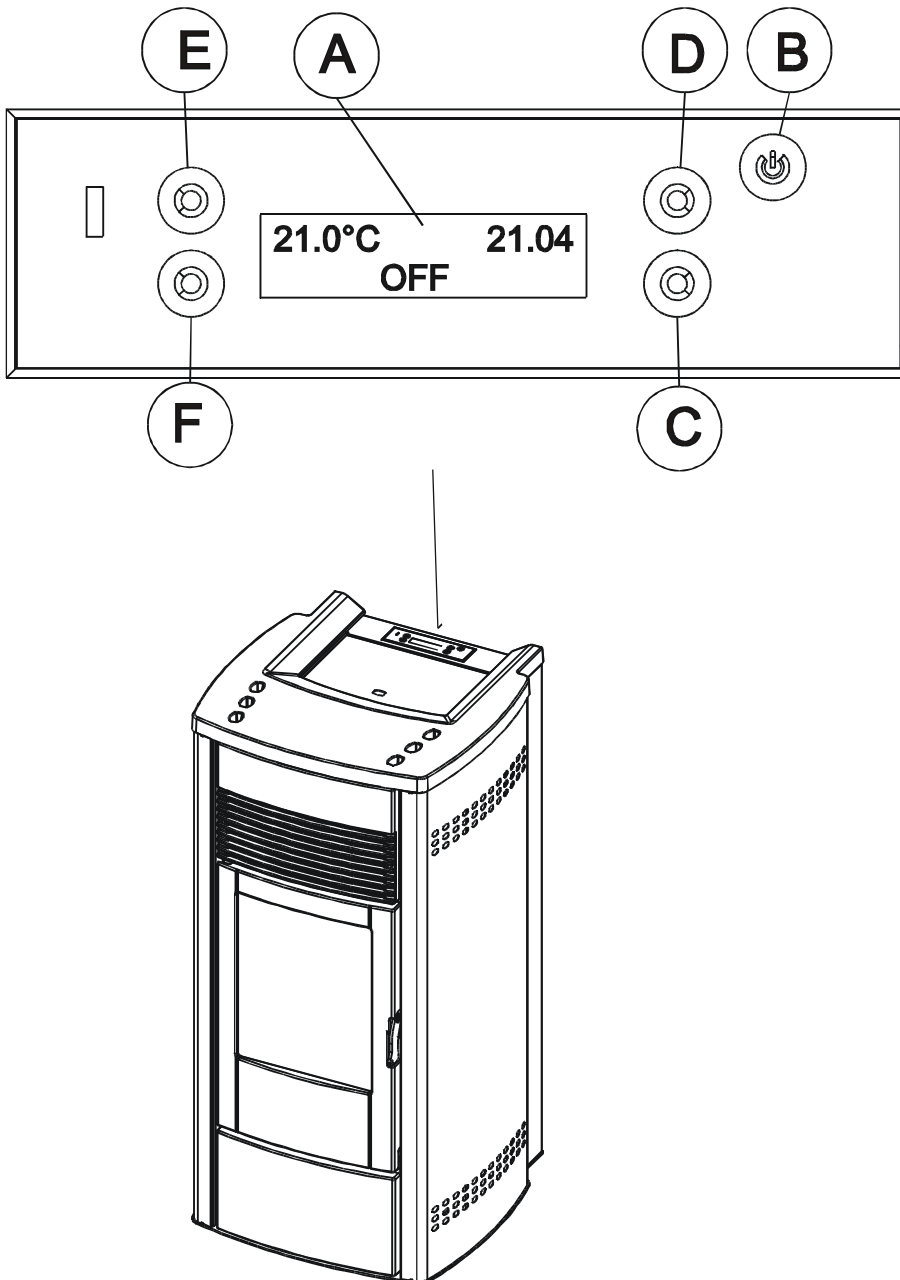

**KEY**

- A.** Display; indicates a series of information about the stove, as well as the identification code for any operating anomaly.
  - B.** ON/OFF key or ESC (exit the menu).
  - C.** Programme selection key (next screen)
  - D.** Programme selection key (next screen)
  - E.** Programme selection key (next screen)
  - F.** Programme selection key (next screen)
- N.B. on the control panel it will be possible to set the language



## 4.8. SETTINGS TO CARRY OUT BEFORE FIRST LIGHTING

Once the power cord is connected to the rear part of the stove, place the switch, also on the rear, to position **(I)**.

The lighted button of the switch will come on.

The switch located to the rear of the stove powers the system.

The stove is off and on the panel the first screen appears with the word **OFF**; by pressing any key the screen with the word **MENU** will appear.

### 4.8.1. Setting current day and time

By pressing the key concerning **MENU** the word **SET** will appear. Type **SET** and the programme will appear to change:

Hour

Minutes

Day

Day of month

Month

Year

To modify the time, for example, when **TIME** appears on the display, press **SET**, the time will begin to flash in the centre of the display. With the lower left or right keys modify the hour and subsequently the minutes, day etc... etc... in the same way and according to need. All the modification made must be confirmed by pressing **OK**, otherwise they will not be saved. The **ESC** key returns to the previous screen without saving the modifications.



**If for 10 seconds the keypad of the control panel is inactive, it returns to the start screen without saving the modifications.**

### TIME ADJUSTMENT

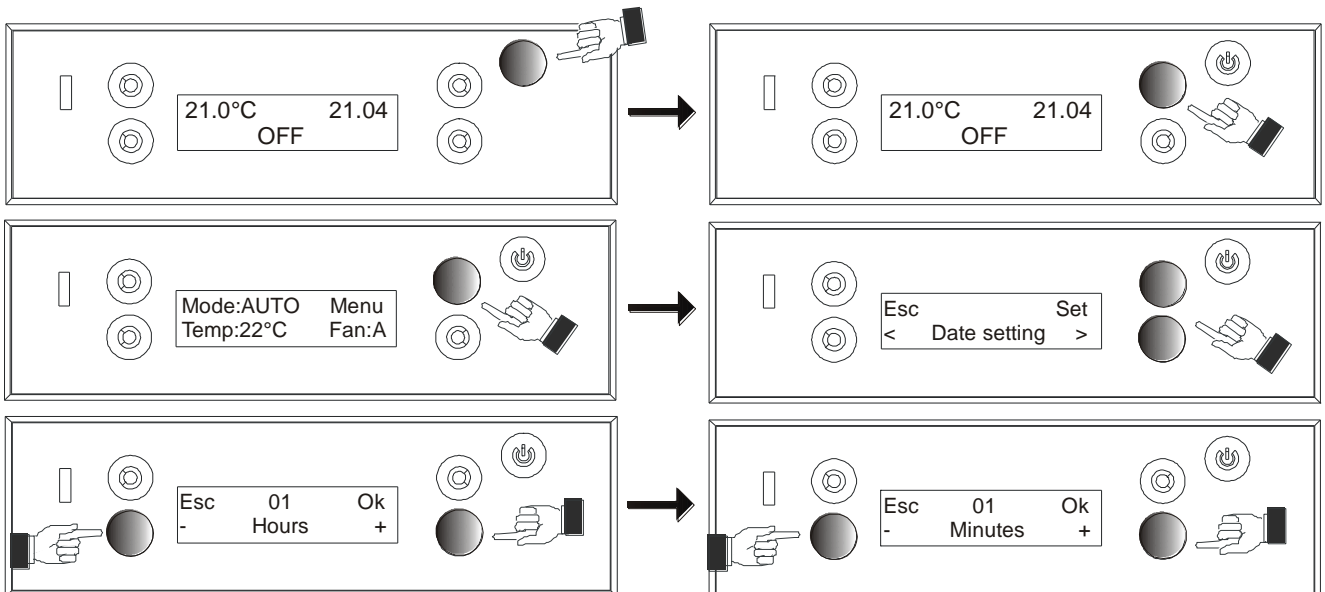

**DAY/DAY NUMBER/MONTH/YEAR ADJUSTMENT**

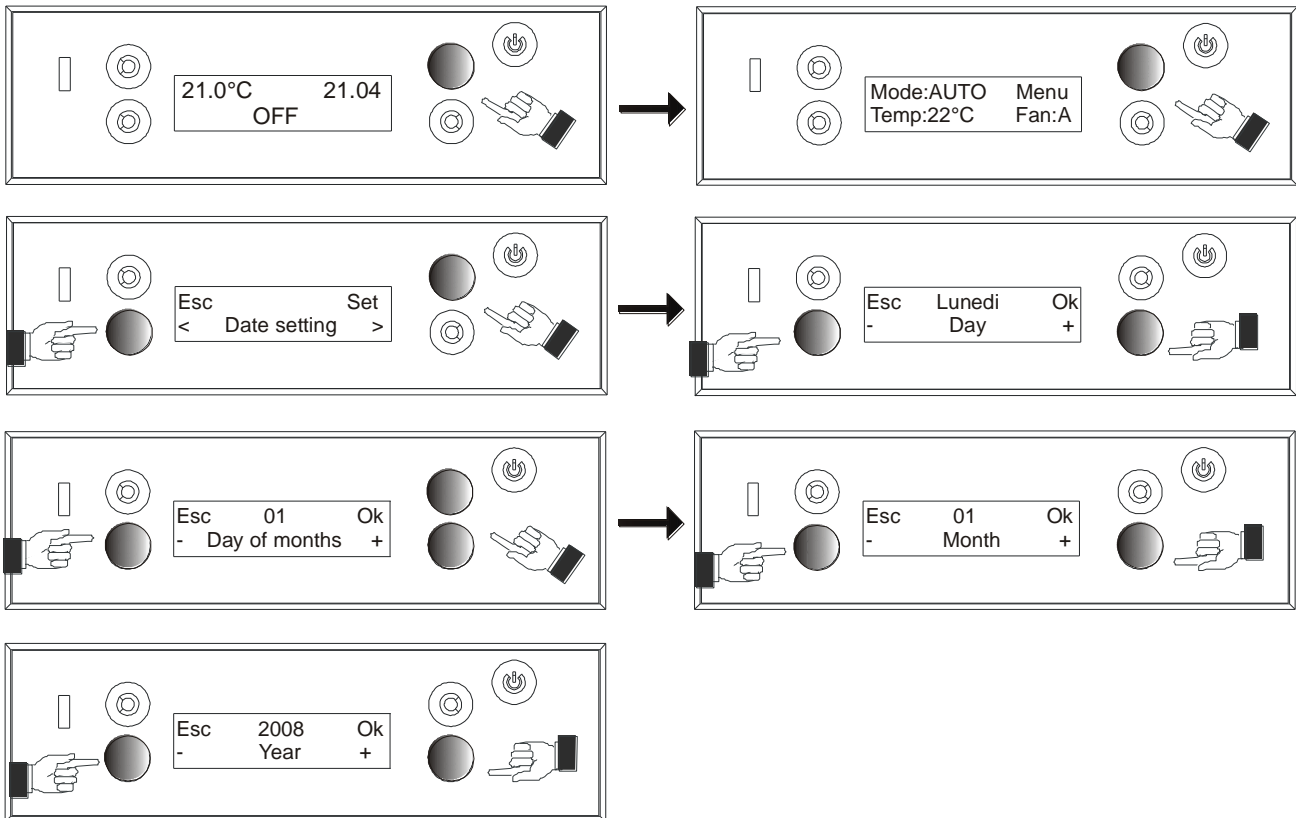

**4.8.2. Setting the language**

From the start screen, press any key and the screen with the word **MENU** will appear.

Press the key concerning **MENU** then scroll with the keys downwards to the right until the word **SETTING/IMPOSTAZIONI** appears, press **SET** and scroll with the keys downwards until the word **LANGUAGE/LINGUA** appears, press **SET** again and set the language chosen.

The following abbreviations are used for the days of the week deriving from the language set in the panel: In the case of English:

- |           |   |           |
|-----------|---|-----------|
| <b>MO</b> | → | Monday    |
| <b>TU</b> | → | Tuesday   |
| <b>WE</b> | → | Wednesday |
| <b>TH</b> | → | Thursday  |
| <b>FR</b> | → | Friday    |
| <b>SA</b> | → | Saturday  |
| <b>SU</b> | → | Sunday    |

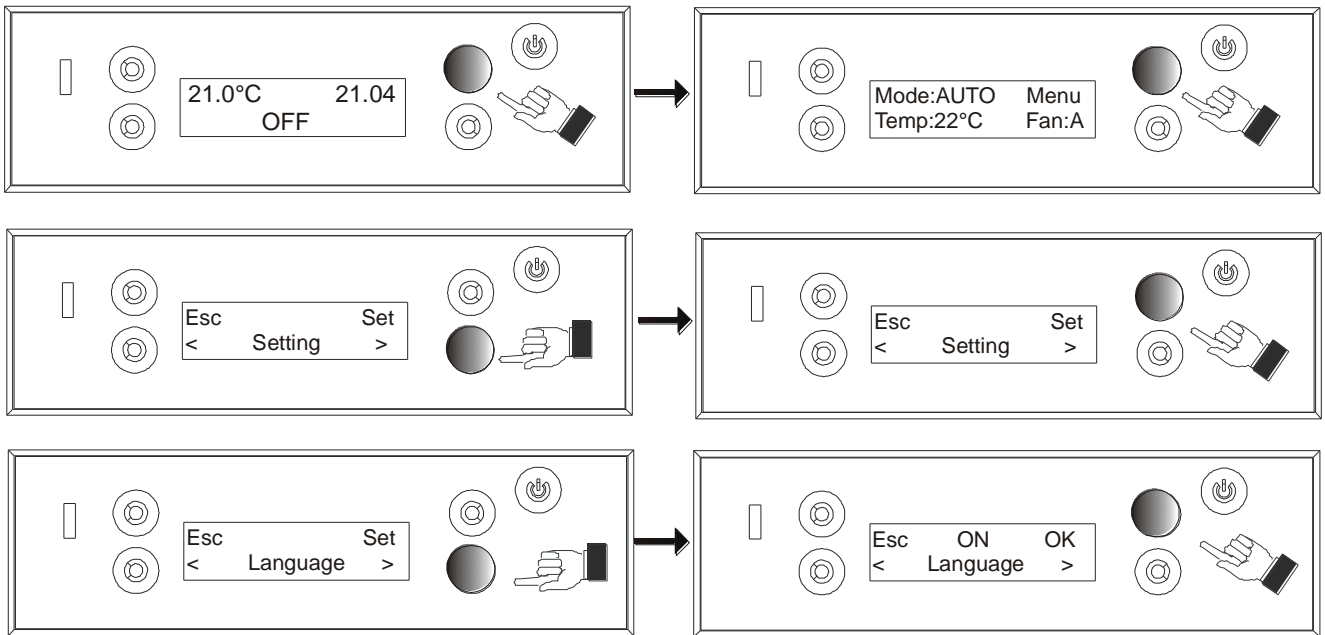

### 4.8.3. Procedure for recipe selection

The message "Recipe" will appear on the control panel menu, under the settings menu. This function is used to increase or decrease pellet loading in the hopper and is represented as follows:

- To increase: +1 +2 +3 which corresponds to 5-10-15% more in comparison to the standard recipe set by the company.
- To decrease: -1 -2 -3 which corresponds to 10-20-30% less in comparison to the standard recipe set by the company

## 4.9. CONTROL OF WATER TEMPERATURE IN BOILER

The stove is already set with a series of standard parameters that allow it to operate properly (water temperature 65°C and room temperature 22°C). The water temperature is shown on the control panel display, which alternates with the room temperature.

If the user wants to change the parameters related to the temperature, it can be done as follows:

### The following parameters can be set:

**T Ambient** From the first screen with the message OFF, press any key and the screen with the message MENU will appear. Using the bottom left button it is possible to adjust the temperature desired in the room.

**T H<sub>2</sub>O =** Maximum temperature of water in boiler. Upon reaching this temperature, the stove will reduce its performance to prevent overheating. The default temperature is 65°C and it cannot be set below 50°C or over 80°C.

To adjust it: **press any button; press the "MENU" button; using the buttons for scrolling, display the "SET TEMP.H2O" screen; press the "SET" button; set the desired temperature using the buttons for scrolling "< >"; confirm the temperature with the "OK" button.**

## 4.10. FIRST LIGHTING

### 4.10.1. Start-up/shutdown from the control panel

The stove is ignited and shutdown by **pressing key B on the control panel for 2 seconds.**

After a start-up phase that lasts about 15 minutes, the stove will come up to full operating power.

After the stove is shut down by pressing button B on the control panel, the cooling-off procedure begins. This includes the interruption of fuel loading, the cleaning of the grate and the continuation of ventilation until the stove is sufficiently cold. This phase may last from 20 to 40 minutes depending on how long the stove was lit and its position.

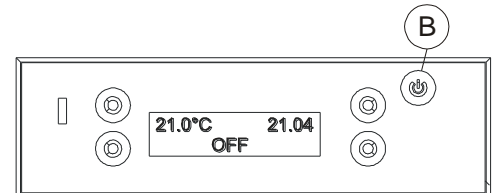

### 4.10.2. Note on first ignition



**The first attempt at ignition may not be successful, since the feeder screw is empty and it is not always able to fill the grate with required amount of pellets in time to ensure normal ignition.**



**If the screw feeder is empty, use the control panel to activate manual screw feeder loading.**



**CANCEL THE ALARM CONDITION FROM THE CONTROL PANEL (see paragraph 4.14)., REMOVE PELLETS IN THE GRATE AND REPEAT LIGHTING**

After repeated attempts at lighting, if there is no flame even though pellets are flowing normally, check that the grate is correctly positioned. It must be **placed where it adheres perfectly to its housing and free of any ash incrustations.** If after this check no abnormalities are found, it means that there may be a problem with the stove components or that installation may not have been carried out correctly.



**REMOVE THE PELLETS FROM THE BURNER AND CONTACT AN AUTHORISED MCZ TECHNICIAN.**

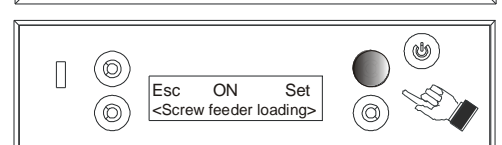
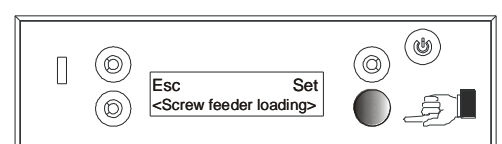
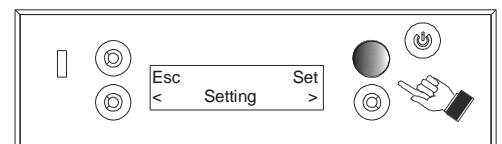
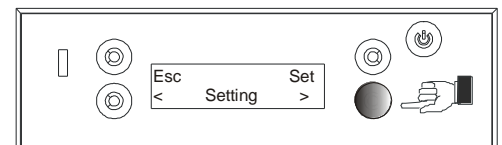
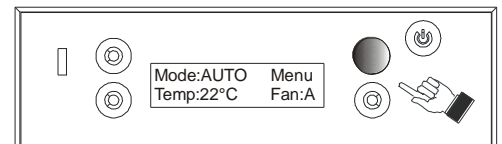
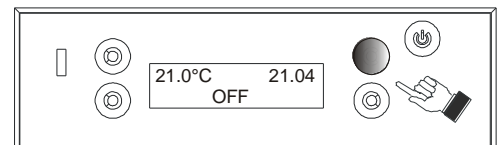

Screw feeder loading

## 4.11. OPERATING MODE

### 4.11.1. Operating concept

**AUTOMATIC** mode lets you set the desired temperature in the room of installation. The stove will control its power autonomously in order to reach and maintain the established temperature in the room. This mode is indicated by the message **AUTO** on the control panel.

It is also possible to use an advanced function called **AUTO-ECO** that will be explained below (*section 4.9.3.*)



**At each lighting, the stove automatically sets to the operating mode that it was in the last time it shut down.**

### 4.11.2. Automatic mode

The **AUTOMATIC** mode lets you set a temperature to be reached in the room. In this operating mode the stove will automatically vary the thermal power provided so as to keep the temperature in the room constantly at the set value.

Upon reaching the desired temperature in the room, the stove will gradually go to minimum power. If instead the room temperature drops below the set limit, the stove will gradually come back up to maximum hearing performance.

The room temperature is highlighted by the control panel using the reading of the probe placed near the switch of the stove.

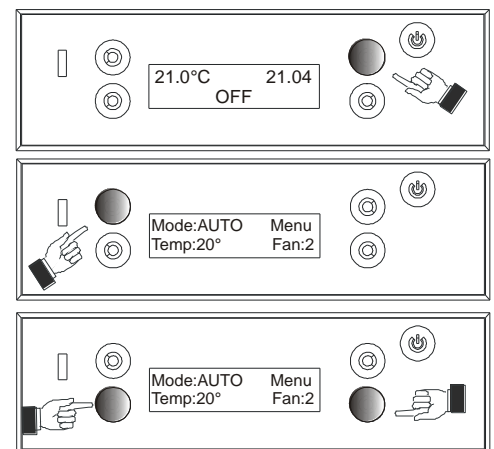

Automatic mode

#### 4.11.2.1. Room sensor

The room probe (**B**) is located at the back of the stove; **should this be near the fumes exhaust tube**, we recommend to extract the room probe so that it sticks out by approximately 10 cm. In this way it will not be affected by the tube's heat and the measured temperature will be near to that of the room.

It is advisable to do this operation during installation, since before extracting the probe (**B**) it is necessary to take off the clamp (**C**) that keeps it connected; operation possible by working inside the stove thus without the sides. To extract the probe (**B**) it is necessary to unscrew the protection cap (**A**) and slowly pull the probe (**B**). After extracting the probe (**B**) sufficiently, close the protection cap (**A**) again. (fig.11)



**ATTENTION!** Once the clamp that binds the probe wire is taken off, avoid it coming into contact with the hot parts of the stove.

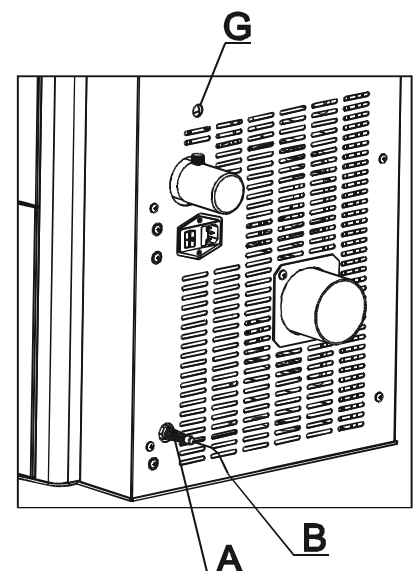

Fig.11 - Room temperature sensor

**4.11.2.2. Connecting an external room thermostat (3) or storage tank (3)**

The stove can be connected to an external thermostat "3" or to a domotic control unit "4".

To make this connection, insert the wires in the board at the back of the stove in the positions specified in the table.

When managing an external thermostat and a storage tank, the connection needs to be made to terminal "3", whereas in the event of a connection to a domotic control unit, then the connection needs to be made to terminal "4". If you wish to connect the modem, then use terminal "2"

**We recommend these connections be made by a specialised technician.**

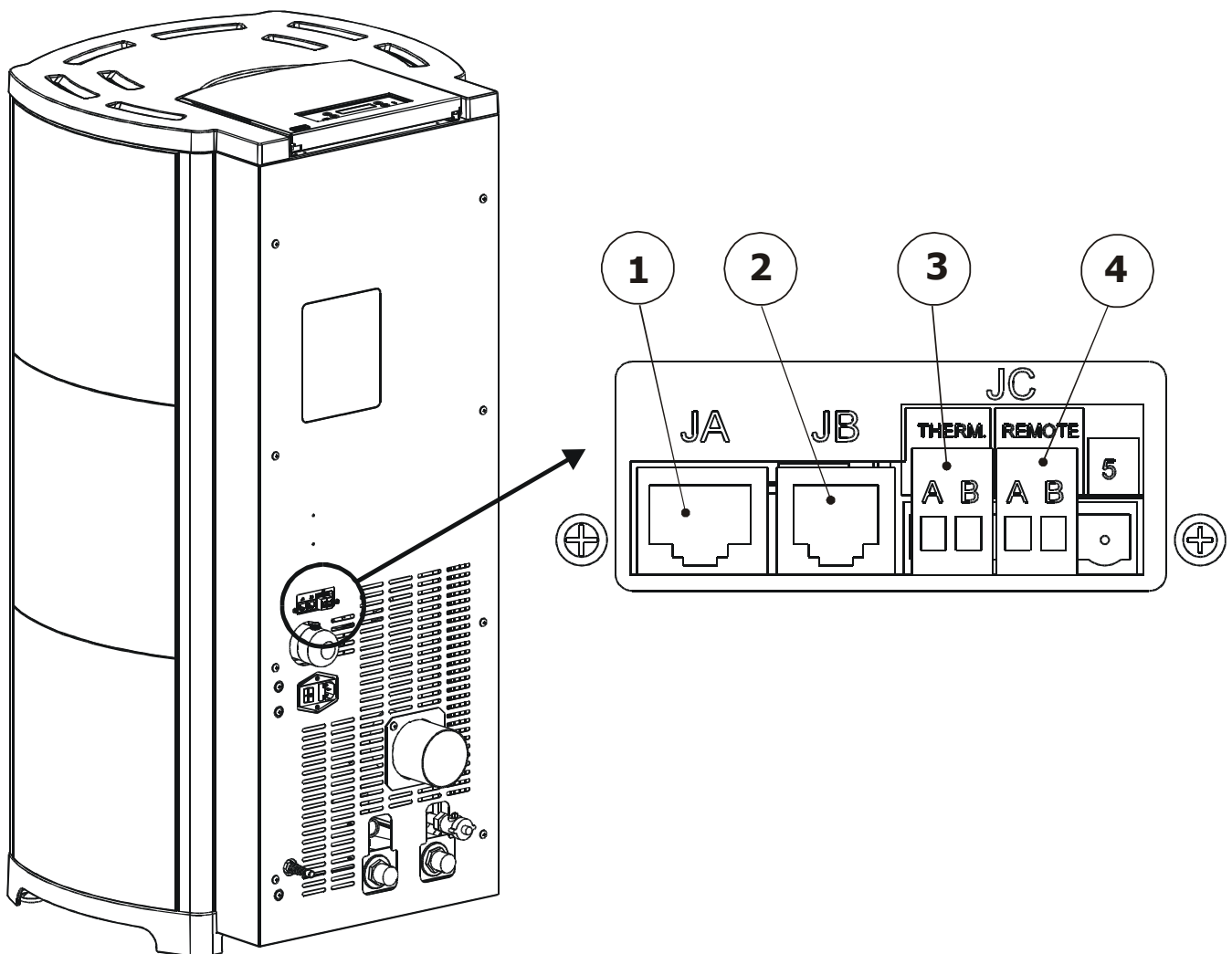

1	COMPUTER CONNECTION (to be made by a specialised technician)
2	MODEM CONNECTION
3	CONNECTION TO AN EXTERNAL ROOM THERMOSTAT CONTROL UNIT
4	CONNECTION TO A DOMOTIC CONTROL UNIT

On the control panel of the stove, once the thermostat is connected, the temperature detected by the probe will continue to appear; however, in this case the temperature set on the thermostat will be valid.

The activation of the thermostat (on/off) on the control panel or of the accumulation tank is possible from the menu, settings, on/off option thermostat or accumulation as explained in the diagram below.

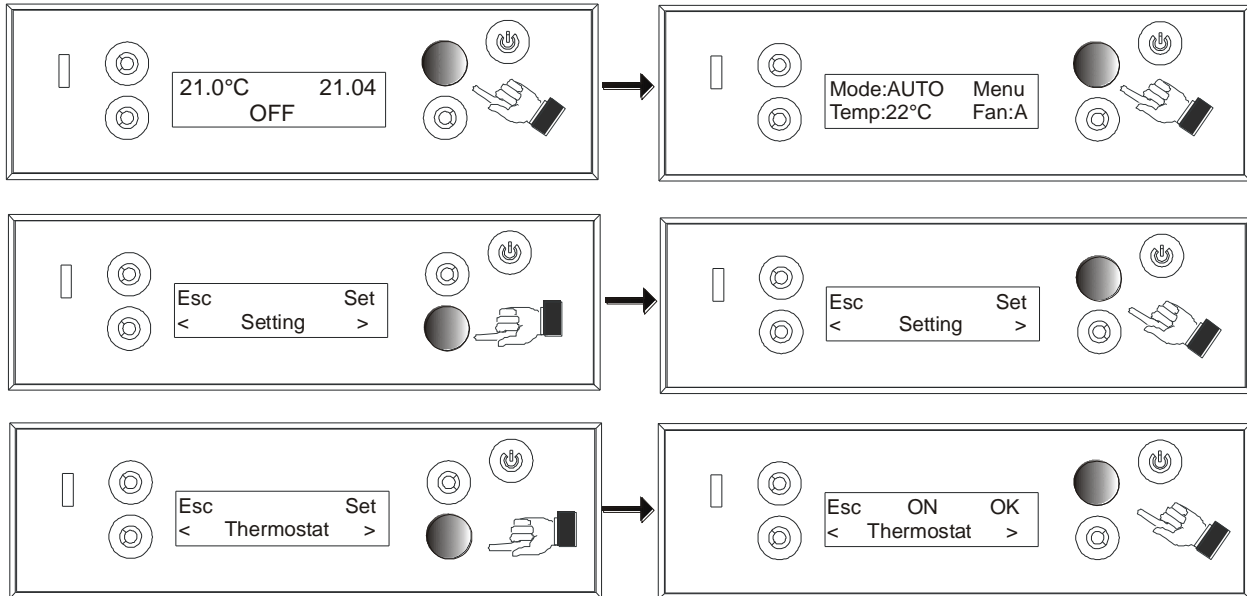

### 4.11.3. Automatic mode with AUTO-ECO

This mode changes stove operation in automatic **mode**. Upon reaching the temperature set by the user, the stove goes to power 1 for a short period of time. The stove comes back on automatically only when the room/water requires heat again, but not before a period of time has passed for the stove to cool off. This option is advisable only if the stove works in rooms where there is low heat dispersion over time.

### 4.11.3.1. Activation /de-activation of AUTO-ECO mode

This mode makes it possible to optimize stove consumption in well-insulated rooms.

When this option is activated, on the display of the control panel the word **AUTO-ECO** will appear.

The display of the remote control will show the message **AUTO** along with the message **AUTO-ECO**.

From the first screen with the word OFF, press any key and the screen with the word MENU will appear.

With the bottom right button scroll until the word SETTINGS, press the top left key SET, scroll with the bottom right key until the word AUTO-ECO appears. Select SET again in the top right and with the bottom right key set OFF or ON and press OK to save the setting. Now going back to the initial menu you notice that the setting on the Mode is ECO. Therefore, using the bottom left or bottom right keys it is possible to set the temperature and the fan speed respectively, for the expulsion of hot air.

To disable the AUTO-ECO function follow the same procedure.

#### **Example of operation in AUTO-ECO mode**

If the room temperature detected by the sensor and highlighted on the control panel is 15°C and the set temperature is 20°C, the stove will follow a pre-established ramp up to the 5<sup>th</sup> power. Once 20°C is reached, it will go into standby mode (STANDBY).

When the room temperature drops below the value set on the control panel (for example 18°C) and a sufficient shutdown time has elapsed, the stove will come back on automatically and continue running until again reaching 20°C. If the temperature read by the room sensor remains above the value set on the thermostat (for example 20-21°C) the stove will remain off.

In this mode, lighting can be carried out by the user by resetting the thermostat temperature to a value greater than that in the room, or by shutting down the stove by pressing button **B** for a few seconds and then pressing the same button to re-light the stove.

The "**AUTO-ECO**" mode does not need to be reset as it remains in memory from the last use.

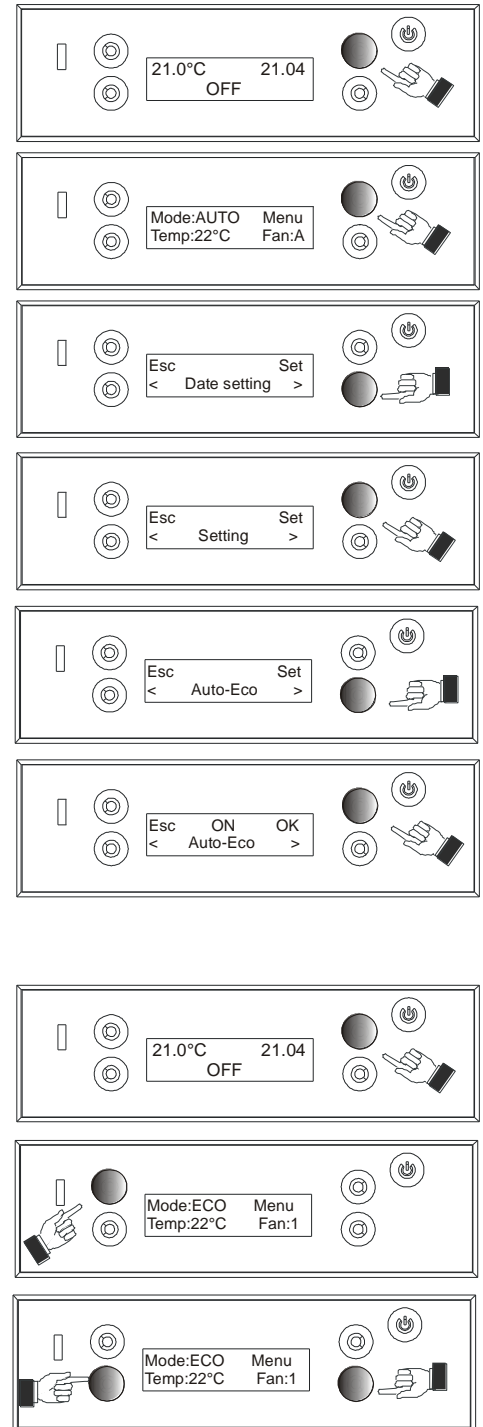



## 4.12. HOT AIR VENTILATION SUITE-CLUB-MUSA 22 KW

The **Suite-Club-Musa 22 kW** stoves are equipped with an internal fan for expulsion of heating air. It can be set to 5 different speeds at any time.

**5** speeds can be selected as well as an automatic function.

To select the speed, after pressing the bottom right button, press it again to increase or decrease the fan power. In addition to the **5 speeds** there is an additional selection called AUTO function (shown on the panel after the 5 speeds with an **A**). This function autonomously selects the speed of the fan irrespective of the flame's power level.

This option can be simply selected by always pressing the bottom right key, scrolling through the various speeds 1-2-3-4-5. On the control panel the letter **A** will appear.

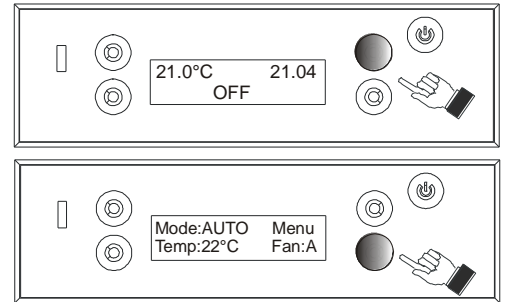

**If the keypad on the control panel is inactive for 10 seconds, the remote control will automatically exit fan setting mode and will confirm the last inserted setting.**

### 4.13. SLEEP FUNCTION

The purpose of this function is to make it faster to select a programmed shutdown, without the need to programme the stove's internal timer.

To explain the SLEEP function in simple terms, it might be said that it allows the stove to be turned off starting from a minimum of 10 minutes in comparison to the read hour (example, if it is now 8:50, the first shutdown can occur after 10 minutes, that is at 9:00) and a maximum during the day of 23.50 hours.

It is specified that the SLEEP function can be activated and appears on the display only when the stove is lit, i.e. when the button B is kept pressed and the word **LIGHTING** appears on the display.

To set the function press **Menu** with the top right key then in the screen the word **Date and Time** appears, therefore scroll with the bottom right key until the word **Sleep** appears, confirm with **Set**. With the bottom right key set the shutdown time.

The figures **00:00** appear in the centre of the display of the control panel; it is possible to choose the quantity of time by pressing the bottom right or left key according to whether you want to increase or decrease the time.

To confirm the choice press **OK** (top right) otherwise quit without saving any setting with **ESC** (top left)



**Once the sleep is set, in the initial screen the status of the stove (on/off) alternates with the message sleep 14.50 (example).**

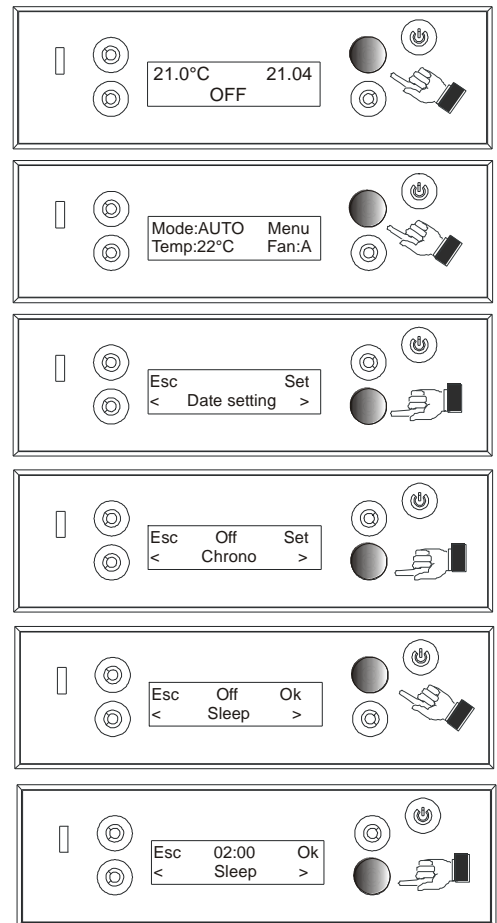

### 4.14. TIMER

This operating mode allows the programming of the start-up and shutdown of the stove in automatic mode.

**Normally, the stoves have the PROGRAMMED mode deactivated.**

The basic settings in PROGRAMMED mode are:

- **Clock**
- **Current day**
- **Selection of weekly / daily programme**

#### 4.14.1. Current date and clock

See *paragraph 4.6.1.* to learn how to set the current date and time.



**Setting the current date and time is essential for proper timer operation.**

### 4.14.2. TIMER activation and selection of a programme.

#### **SETTING OF A WEEKLY PROGRAMME**

An explanation will now be provided of how **to activate the TIMER function selecting a daily or weekly programme:**

Press the Menu button to scroll through the date and time menu with the relative key until the word **TIMER** appears. Then press the SET key to insert a programme. In the centre of the display between Esc and Ok the letters **P00** appear, by scrolling with the keys below it is possible to choose between 1 10 weekly preset programmes inside the control panel of the stove.

According to the tables reported in *paragraph 4.11.*, choose the programme that best meets the heating needs of the house and save the programme number on the display of the control panel. Confirm with OK.

If none of the 10 pre-set programmes meets your personal heating needs, you can put together a personalized weekly programme that suits you best (see next paragraph).



**If the keypad of the control panel is inactive for 10 seconds the control panel automatically leaves the timer adjustment mode and does not confirm the last setting inserted.**

To confirm the TIMER choice press OK.



#### **ATTENTION!**

**The TIMER function can be activated/deactivated whether the stove is on or off.**

**If a timer programme has been activated, in the initial screen the stove operating status (on/off/start-up....) alternates with the word "TIMER P01 active" (example)**

#### **SETTING OF A PERSONALIZED PROGRAMME**

If one of the pre-set weekly programmes does not suit the heating needs for your home, you can choose and combine various daily programmes included in the memory of the control panel to create a personalized weekly programme.

**62 daily programmes can be selected, and you can select a different programme for each day of the week.**

To activate this option, proceed as described above for setting a weekly programme, but instead of selecting one of the programmes contained in the table of the weekly programmes (**from P01 to P10**) select the programme **USER**.

Once the USER programme is selected, press SET and in the centre of the display the word Lu P00 appears (where P00 flashes) while in the part below, the word CUSTOMIZE appears, by pressing the related key (bottom right or left) it is possible to insert the daily programme.

By scrolling with the bottom right or left key of the control panel it is possible to choose the desired programme from 1 to 62, by consulting the table in par. 4.13.2

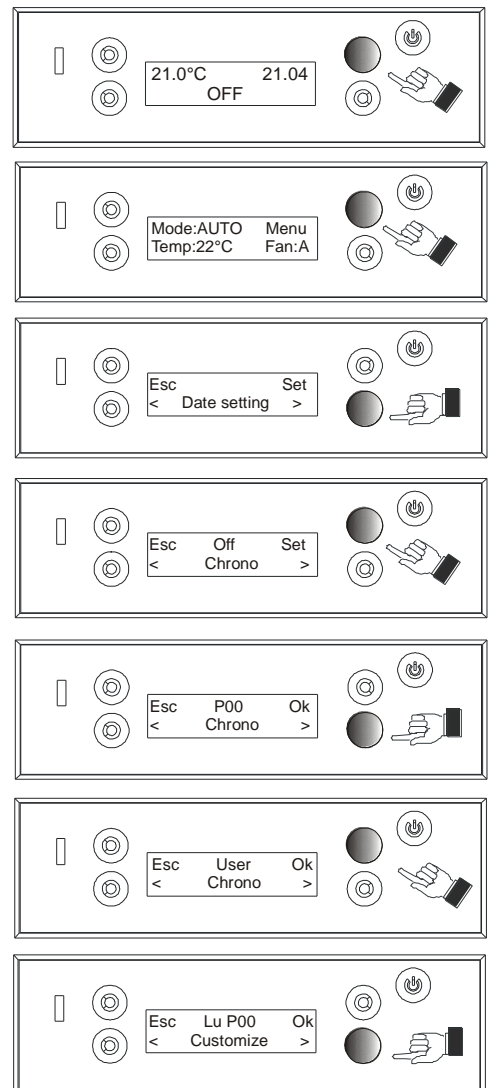

Once the desired programme is selected for the active day (e.g. 32 for the day MO = Monday), press the OK key in the top right and on the display the word Ma P00 will appear (where the word P00 flashes), proceed with the programming mode until the day SU=Sunday.

**If for a given day of the week you do not want to set any programme, select programme 00 and continue with programming.**



**If a timer programme is active but the user decides to start/stop the stove in advance, the command given by the user overrides the timer and is carried out. The next command from the timer is obviously disregarded.**

**Example: if the timer calls for the stove to be started up at 10:00 but the user decides to start it at 9:00, by pressing button 5 the stove will come on. At 10:00, the timer, which was to order start-up, will be disregarded.**



### **IMPORTANT NOTE**

It takes 10 to 15 minutes for the stove to start up.



Take this into account when setting the start time. Likewise, stove shutdown requires about 30 minutes, during which the heat stored up by the stove is still released into the room.

Keep this in mind for substantial fuel savings.

#### **4.14.3. TIMER de-activation.**

To de-activate the timer, access the menu again by means of button **OFF**.

### **4.15. PRE-SET WEEKLY AND DAILY PROGRAMMES**

#### **4.15.1. Weekly programmes**

The weekly programmes selected by MCZ and stored in the memory of the control panel were designed to meet the needs of most users who are out of the home during working hours (factory workers, shopkeepers, office workers, shift workers) as well as those who are usually at home (homemakers, senior citizens, etc.).

Also, programming has been provided for those who use the stove in a weekend home (e.g. a home in the mountains) and want to find the home warm when they get there.

If you have even more specific needs which are not met by any of these weekly programmes, you can customize weekly programme P99 using seven different programmes for each single day of the week (see chapter 4.13.2).

PROGRAMMES		HOURS																									
No.	DAYS	0.00	1.00	2.00	3.00	4.00	5.00	6.00	7.00	8.00	9.00	10.00	11.00	12.00	13.00	14.00	15.00	16.00	17.00	18.00	19.00	20.00	21.00	22.00	23.00	0.00	
P01	Mon-Fri																										
	Sa-Su																										
P02	Mon-Fri																										
	Sa-Su																										
P03	Mon-Fri																										
	Sa-Su																										
P04	Mon-Fri																										
	Sa-Su																										
P05	Mon-Fri																										
	Sa-Su																										
P06	Mon-Fri																										
	Sa-Su																										
P07	Mon-Sa																										
	Su																										
P08	Mon-Sa																										
	Su																										
P09	Mon-Sa																										
	Su																										
P10	Fri																										
	Sa-Su																										

On  
 Off

### 4.15.2. Daily programmes

Progr.	Hours																										
N°	0.00	1.00	2.00	3.00	4.00	5.00	6.00	7.00	8.00	9.00	10.00	11.00	12.00	13.00	14.00	15.00	16.00	17.00	18.00	19.00	20.00	21.00	22.00	23.00	0.00		
00																											
01																											
02																											
03																											
04																											
05																											
06																											
07																											
08																											
09																											
10																											
11																											
12																											
13																											
14																											
15																											
16																											
17																											
18																											
19																											
20																											
21																											
22																											
23																											
24																											
25																											

Programmi giornalieri	Tabella orari																											
	N°	0.00	1.00	2.00	3.00	4.00	5.00	6.00	7.00	8.00	9.00	10.00	11.00	12.00	13.00	14.00	15.00	16.00	17.00	18.00	19.00	20.00	21.00	22.00	23.00	0.00		
26																												
27																												
28																												
29																												
30																												
31																												
32																												
33																												
34																												
35																												
36																												
37																												
38																												
39																												
40																												
41																												
42																												
43																												
44																												
45																												
46																												
47																												
48																												
49																												
50																												
51																												
52																												
53																												
54																												
55																												
56																												
57																												
58																												
59																												
60																												
61																												
62																												

## 4.16. PRACTICAL EXAMPLE OF DAILY PROGRAMMING

### 4.16.1. Setting of a daily programme

Let's look at a user who does not have regular daily hours (a free-lance worker, for example), but who generally expects to be at home at the following times:

- MONDAY → home until 10:00 and from 17:00 on
- TUESDAY → home until 8:00 and from 14:00 on
- WEDNESDAY → at home all day and does not wish to set any programme
- THURSDAY → at home all day

- FRIDAY → at home until 9:00, from 12:00 to 15:00 and from 18:00 on
- SATURDAY → at home only after 18:00
- SUNDAY → at home only after 14:00

Based on these times, from the table in paragraph 4.11.2 the daily programmes are selected which best suit this routine.

- MONDAY → Programme **20**
- TUESDAY → Programme **43**
- WEDNESDAY → Programme **00**
- THURSDAY → Programme **13**
- FRIDAY → Programme **34**
- SATURDAY → Programme **10**
- SUNDAY → Programme **08**

To activate this type of customised setting follow the instruction in par. 4.11.2 page 48.

#### **4.17. SAFETY DEVICES**

The stove is fitted with the following safety devices:

- **SMOKE TEMPERATURE SENSOR.**  
Monitors the temperature of the smoke, and gives permission for start-up or shuts the stove down when the smoke temperature falls below the preset value.
- **PELLET HOPPER TEMPERATURE SENSOR.**  
If the temperature exceeds the preset safety level, it immediately shuts down the running of the stove, and has to be reset, after the stove has cooled, before the it will restart.
- **BOILER TEMPERATURE PROBE (ALARM A18)**  
If the temperature of the water approaches shutdown temperature (95°C) the stove will shut down.
- **WATER TEMPERATURE PROBE (ALARM A17)**  
When the water temperature reaches 80°C the stove starts to gradually decrease the power to 85°C. If 85 °C is exceeded, a safety shut down will occur and the stove will re-start when the stove body has properly cooled.
- **ELECTRICAL SAFETY**  
The stove is protected against violent surges of current by the main fuse, which is located on the control panel at the rear of the stove. Other fuses to protect the electronic boards are to be found on the boards themselves.
- **FAILURE OF THE SMOKE EXTRACTION FAN**  
If the fan stops, the electronic board shuts off the supply of pellets in good time, and an alarm is displayed.
- **BREAKDOWN OF THE REDUCTION MOTOR**  
If the reduction motor stops, the stove continues to function until it has cooled down to the minimum level.



- **TEMPORARY POWER CUT**

If there is a power outage during operation, when the power comes back on the stove will go into cooling mode and then it will come back on automatically.

- **FAILURE TO LIGHT**

If during ignition no flame develops, the stove will go into alarm condition.

- **ANTI-FREEZE FUNCTION**

If the probe in the boiler detects a water temperature of less than 5°C, the circulation pump is automatically activated to keep the system from freezing.

- **PUMP ANTI-SEIZURE FUNCTION**

If the pump is not used for prolonged periods, it is activated periodically for 1 minute every 24 hours of inactivity to keep it from seizing up.



**TAMPERING WITH THE SAFETY DEVICES IS PROHIBITED**

It is only after eliminating the cause which gave rise to the intervention of the safety system, that it is possible to relight the stove and thus reset the automatic operation of the sensor. To understand which anomaly has occurred, consult this manual at paragraph 4.14 which explains what to do based on the alarm message the stove displays.



**ATTENTION**

**If the stove is not used as described in this instruction booklet, the manufacturer refuses to accept any responsibility for damage to persons and property that may arise. The manufacturer furthermore refuses to accept responsibility for damage to persons and property arising from the failure to observe all the rules contained in the manual and in particular:**

- **Failure when carrying out works of maintenance, cleaning and repair to adopt all necessary measures and precautions**
- **Tampering with the safety devices.**
- **Removing the safety devices.**
- **Failure to connect the stove to an efficient system for the discharge of smoke.**
- **Failure to check in advance that the room where the stove is to be installed is adequately ventilated.**

#### **4.18. ALARM SIGNALLING**

Should an operation problem occur, the stove enters a shutdown phase for alarm and informs the user of the type of fault that occurred using a 3 digit code that remains displayed on the control panel of the stove (and a short description of the alarm type)

The table below describes the possible alarms signalled by the stove, associated to the respective code that appears on the emergency panel, and useful suggestions to solve the problem.

MESSAGE ON DISPLAY	TYPE OF PROBLEM	SOLUTION
<b>A01</b>	The fire does not ignite.	Check the level of pellets in the tank. Check that the brazier rests correctly in its seat and has no visible deposits or unburnt pellets. Check whether the ignition plug becomes hot. Empty and clean the brazier before relighting.
<b>A02</b>	Fire extinguishes abnormally	It derives from a shutdown due to lack of fuel (hopper empty).
<b>A03</b>	Pellet tank temperature exceeds foreseen safety limit. Overheating of the stove body	The structure is too hot because the product has been operating for too long at maximum power, or it is poorly ventilated, or the air fans are faulty. When the stove is sufficiently cold, press button B of the control panel to cancel the alarm A03. Once the alarm is cancelled it is possible to relight the stove normally.
<b>A04</b>	The temperature of the smoke discharge has exceeded pre-set safety limits	The stove will shut off automatically. Let the stove cool off for a few minutes, then re-light it. Control the exhaust of the smoke the type of pellet being used.
<b>A05</b>	Flue pipe obstruction - wind - door open.	Check fume conduit and door closure.
<b>A06</b>	The smoke extractor is not able to provide the primary air required for combustion.	Draught difficulties or clogging of grate. Check whether the grate is clogged by incrustation and clean as required. Control and if necessary clean the smoke duct and the air intake.
<b>A08</b>	Flue-gas exhaust fan broken	Check that the smoke fan compartment is clean and if it is dirt that is blocking it. If insufficient, the smoke fan is defective. Call an authorized service centre to make the replacement.
<b>A09</b>	The smoke probe is defective and does not properly measure the temperature of the discharge smoke	Contact an authorized service centre to replace the component.
<b>A10</b>	The plug is defective	Contact an authorized service centre to replace the component.
<b>A11</b>	Defective pellet feeder	Contact an authorized service centre to replace the component.
<b>A14</b>	Generic failure of sensor	This alarm is not blocked, only a warning screen appears. Contact an authorized service centre to replace the component.
<b>A17</b>	Water temperature too high due to: <ul style="list-style-type: none"> <li>• Stove at maximum power, radiators closed</li> <li>• System oversized e.g. small room, large capacity stove</li> </ul>	This alarm is not blocked, only a warning screen appears. Check that all radiators are open. If the alarm persists contact an authorised service centre.
<b>A18</b>	Water tank temperature too high	This alarm intervenes when the water does not circulate in the system and therefore the temperature increases. Check the pump and release it if necessary. If necessary, contact an authorized service centre to replace the component.
<b>Service</b>	Periodic maintenance warning	If this flashing messages appears when lighting the stove, it means that the hours of operation pre-set before the maintenance have elapsed and a new maintenance intervention is necessary. Contact a specialist MCZ technician.

## 4.19. Exiting alarm condition

In case of an alarm intervening, to restore the normal operation of the stove press the on/off key for a long time. After a short verification phase if the cause that caused the alarm does not persist, the stove leaves the alarm status and it may restart.

### 4.19.1. Shutdown of the stove



**NEVER open the appliance door whilst the stove is either in the initial startup or on its shut down cycle, pellets will still be smoldering or therefore volatiles may be present.**



**ATTENTION!**

**If during operation or initial ignition you encounter smoke spillage in to the room from the appliance or the flue then please switch off the appliance, ventilate the room and contact the installation / service engineer immediately.**

The following things can cause stove shutdown:

- Overheating of the stove body ("**A03**")
- Overheating of the smoke ("**A04**")
- During the function of the stove, an uncontrolled air intake occurred in the combustion chamber or an obstruction in the flue pipe. ("**A05**")
- Boiler overheating ("**A18**")

**WHAT TO DO:**

When the stove is cold: if the message "**A03**" appears: The structure is too hot because the product has been operating for too long at maximum power, or it is poorly ventilated, or the air fans are faulty

When the stove is sufficiently cold, press button B of the control panel to cancel the alarm A03. Once the alarm is cancelled it is possible to relight the stove normally.

If the alarm "**A04**" appears the stove shutdown in automatic, leave it to cool down for a few minutes and then re-light. Cancel the alarm and re-light.

If the alarm "**A05**" appears: it is caused by prolonged opening of the fire door or by substantial air infiltration (e.g. smoke fan inspection plug missing). If not caused by these factors control and if necessary clean the smoke duct and the flue pipe.

If the alarm "**A18**" appears: the stove shuts down due to the boiler overheating. This can be caused by a lack of water circulating in the system (pump blocked or faulty). Check that the circulation pump is operating correctly and then cancel the alarm and restart the stove.

**Only after the cause of the blockage has been permanently eliminated can a fresh attempt to relight the stove be made.**

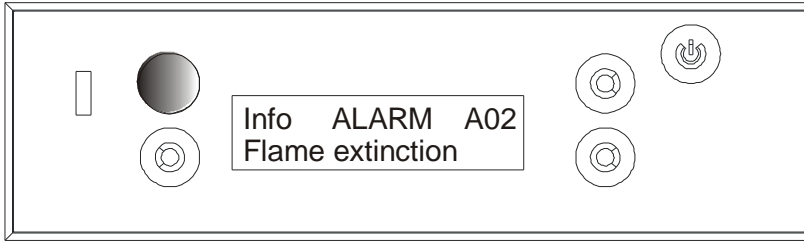

Example: Alarm on the display of the control panel

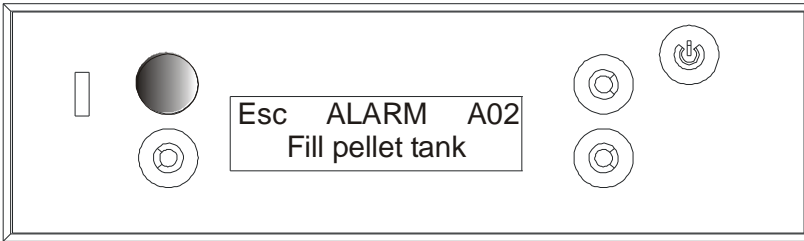

## 5. RECOMMENDATIONS FOR A SAFE USE



**ONLY A SUITABLE INSTALLATION ACCORDING TO THE UK BUILDING REGULATIONS (ADJ) AND A PROPER MAINTAINANCE AND CLEANING OF THE PRODUCT CAN ASSURE YOU THE CORRECT FUNCTIONALITY AND A SAFE USE OF YOUR STOVE.**

**ONLY FOR UK**

We wish to notify you that we have been made aware of incidents involving domestic heating pellet stoves resulting from the stoves having been incorrectly installed or inadequately maintained. In some cases the incident provoked an explosion that caused the glass door on the stoves to shatter.

We would like to assure you that all of our products are very safe and are certified to the required European standards. The ignition system has been tested carefully to increase the lighting efficiency and avoid any trouble even in the worst working condition. Moreover our structures are also provided with a safety device studied to discharge the eventual overpressure in combustion chamber, and avoid any damage to the product and consequent risk for the final user. However, like any stove, our stoves need to be properly installed and maintained if they are to work safely.

Our studies suggest that these explosions are mainly caused by a combination of some or all of the following factors:

- Clogged brazier holes or a deformed brazier, resulting from insufficient maintenance, creating the conditions for a delayed ignition causing a build up of unburnt gases
- Insufficient combustion air due to the stove not having a big enough air inlet or not having an air inlet at all
- The use of smoke connections or flue pipe assembly which don't comply with UK regulations and which don't create the draught required to effectively suck the smoke outside (e.g. too many bends in the flue).
- Partially blocked flue pipes, which indicates poor maintenance, reducing the draw on the chimney making ignition difficult.
- The chimney terminal not complying with our installation instructions and failing to prevent potentially dangerous down-draught. This component becomes essential when the stove is installed in windy areas like coastal zones.

Any of the above factors or any combination of them could generate unburnt gasses which in the worst cases could explosively ignite when there becomes enough oxygen present.

To avoid this rare but not impossible inconvenient, first of all the installation shall be done in compliance with UK building regulations and the suggestions described in this manual.

Furthermore it's absolutely important to respect the following simple rules:

- The brazier shall be always layed down in its proper position before any use of the product, removing completely the dirt if present in the base plate
- Pellets must not be fed manually into the brazier, both before ignition and during the working condition.
- Eventual accumulated unburnt pellets in the burner after a failed ignitions must be removed before lighting

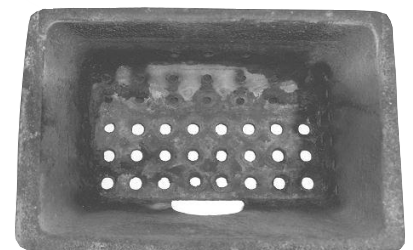

Example of clean grate

- If a failed ignition affects the product repeatedly, despite a clean brazier and a usual fuel loading, we recommend that you immediately stop using the stove and contact a qualified technician to check the stove functionality.

The respect of these suggestions is absolutely enough to guarantee a safe ignition and to avoid any inconvenient to the product.

If the above precautions are not fulfilled, and the ignition shows an abnormal amount of pellet in the brazier and a consequent heavy generation of unburned gas in the combustion chamber, respect carefully the following suggestions:

- Do not switch off the electrical power from the stove for any reason: this would arrest the gas exhaust blower with a consequent spread of smoke into the room.
- Precautionally open the windows to ventilate the installation room from eventual smoke outlet in ambient (the flue gas outlet could work not properly).
- Do not open the fire door: this would affect the regular smoke evacuation from the chimney.
- Simply switch off the stove by pressing the on/off button in the control panel (not the rear button of power supply!), and wait till the smoke has been evacuated completely.
- Before any re-lighting attempt, clean completely the brazier and its air passages from any dirt and unburned pellet; put it in the proper position removing the dirt eventually present in the base plate. If a repeated failed ignition happens, stop using the stove and contact a qualified technician to check the stove and chimney functionality

## 6. MAINTENANCE AND CLEANING

Only a proper maintenance and cleaning of the product can assure you the correct functionality and a safe use of your stove.



**ATTENTION!**

**All the cleaning operations of all parts must be performed with the product completely cold and the plug disconnected.**

**Disconnect the product from the 230V power supply before performing any maintenance operation.**

The product requires little maintenance if used with certified high quality pellets.

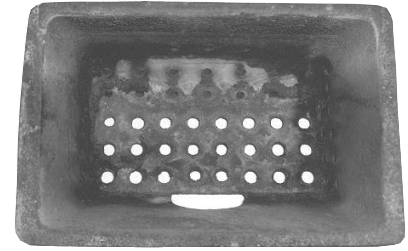

Example of clean grate

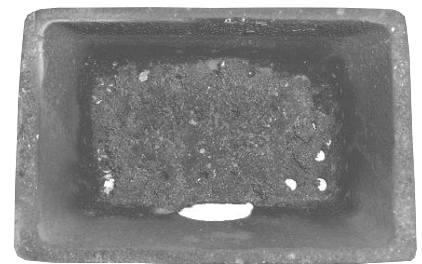

Example of dirty grate

### 6.1. DAILY OR WEEKLY CLEANING PERFORMED BY THE USER

#### 6.1.1. Brazier cleaning

Before ignition, always clean the "T" brazier and remove any ash or incrustation from it that might obstruct the air flow holes, paying attention to hot ash. In the case of ignition failure, or if fuel in the tank runs out, unburned pellets may accumulate in the brazier. Always empty the residue in the brazier before each start-up. Only if ash is completely cold may a vacuum cleaner be used to remove it. In this case, use a suitable vacuum cleaner to remove small sized particles.



**REMEMBER THAT ONLY A CORRECTLY POSITIONED AND CLEAN BRAZIER CAN GUARANTEE THE IGNITION AND OPTIMAL OPERATION OF YOUR PELLET PRODUCT. IN CASE OF FAILED IGNITION AND AFTER ANY OTHER LOCK STATE OF THE PRODUCT, IT IS ESSENTIAL TO EMPTY THE BRAZIER BEFORE PROCEEDING TO RESTART.**

**IF IGNITION FAILS (A01), IT IS IMPORTANT TO REMOVE THE PELLETS LEFT IN THE BRAZIER BEFORE REPEATING THE IGNITION OPERATION.**

For the brazier to be cleaned properly, remove it from its housing completely and thoroughly clean all the holes and the grate on the bottom. If good quality pellets are used, you will normally only need to use a brush to restore the optimal operating conditions of the component.

#### 6.1.2. Ash tray cleaning

Remove and empty the "G" ash tray. Wipe away any residual ash before reinserting the tray. Your experience and the quality of the pellets will determine the ash tray cleaning frequency. However, it is recommended not to exceed 2 or 3 days.

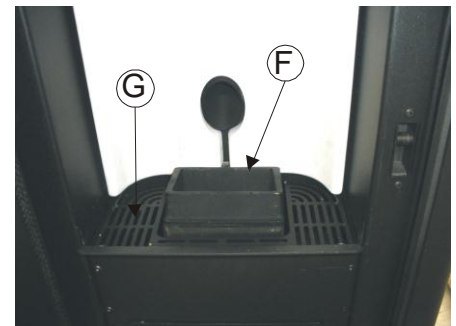

Cleaning the ash collection compartment

### 6.1.3. Clean the exchanger and the undergrate space every 2/3 days.

Cleaning the exchanger and the undergrate space is a simple operation but very important for always maintaining performance as declared by MCZ.

Therefore we recommend cleaning the internal exchanger every 2-3 days, performing these simple operations in sequence:

- **Activate the "CLEANING" function** – when the stove is off, press the key in the control panel highlighted in figure 14 for 2 seconds. This procedure activates the smoke suction fan at maximum power in order to expel the soot which is moved around whilst cleaning the exchanger.
- Remove the top
- **Clean the pipe unit** – Using the cool hand hook supplied, energetically shake the rods located under top **A** in figure 15) 5-6 times.. This operation removes soot deposited in the exchanger's smoke ducts when the stove is working normally.

#### ○ **Clean the smoke conveyor well**

##### **EGO-STAR stoves (Figure 15)**

– Open the door and screw the cool hand to the scraper rod **B** (**B** in figure15), shake it energetically 5-6 times throughout its length. Unscrew the cool hand and reinsert rod **B** completely into its housing. By doing so the fan is assisted in expelling any accumulations of soot which fell when the pipe unit was cleaned previously (After shaking rods "A" it is always necessary to do so with scraper **B**”).

##### **SUITE-CLUB-MUSA stoves (Figure 15A)**

– The Suite-Club-Musa stoves are equipped with a removable ash drawer to collect any build-ups of soot and ashes. To clean the smoke conveyor well with the "CLEANING" function activated, the ash drawer and the door must stay shut.

After activating the "CLEANING" function on the control panel, remove the turbulators "D" and using a rigid rod, clean the pipe unit.

- **Deactivate the "CLEANING" function** by pressing the control panel key highlighted in figure 14 once again.
- Replace the top



**If such cleaning is not done every 2-3 days the stove could go into alarm caused by ash clogging after several hours of operation.**

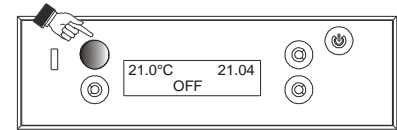

Figure 14 – "Cleaning" function

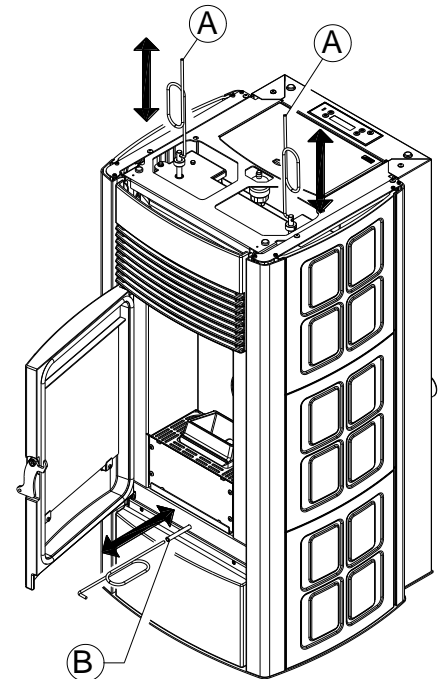

Figure 15 - Cleaning the internal pipe unit using scrapers (EGO-STAR)

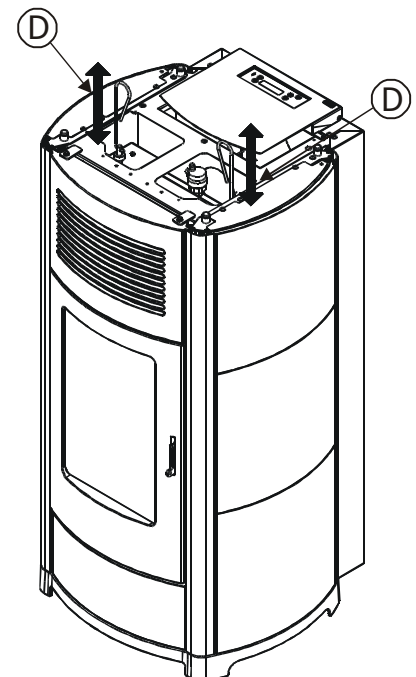

Figure 15 - Cleaning the internal pipe unit using scrapers (SUITE-CLUB-MUSA)



### 6.1.4. Cleaning the glass

For cleaning the ceramic glass, the use of a dry brush is recommended, or if it is very dirty, the special spray detergent, applying a small quantity then cleaning with a cloth.



**ATTENTION!**

**Do not use abrasive products and do not spray the cleaning product on the glass of the painted parts or on the gaskets of the fire door (ceramic fibre cord)**



Cleaning the glass

### 6.1.5. Cleaning of the air filter

At the back of the stove, at the combustion air intake tube Ø 5 cm, there is a metallic mesh air filter. Its purpose is to keep dirt out of the motor body and the internal sensor.

It is advisable to check every 15/20 days whether the filter is clean. Remove lint or any other material which may have been trapped by the filter.

Checking and cleaning will be required more frequently if there are pets in the home.

For cleaning, just turn the knob that holds the filter on the air intake pipe and remove the filter by turning in the direction indicated by the arrow. Clean it with a brush, damp cloth or compressed air.

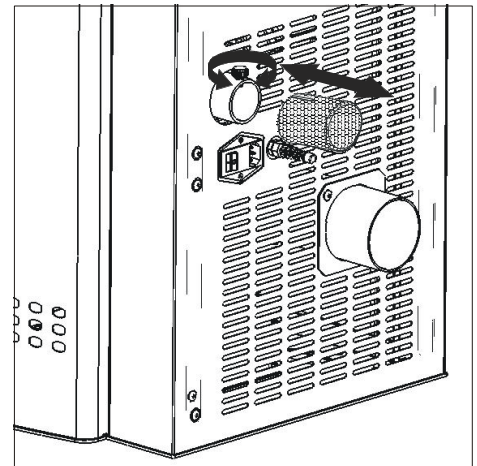

Removing the air filter for cleaning



**The filter is made of metallic mesh. It is soft and malleable to the touch. Therefore, when cleaning it, be careful not to crush it or damage it in any other way. If it is broken it must be replaced**



**ATTENTION!**

**Never operate the stove without the air filter. MCZ shall not be held liable for damage to internal components if this instruction is not followed.**

### 6.1.6. Cleaning of stainless steel and satin-finish surfaces

Normally these surfaces do not need to be treated, but if they do, avoid cleaning them with abrasive materials. For surfaces in stainless and satin brushed steel we recommend cleaning with a paper towel or a clean dry cloth moistened with a detergent based on non-ionic surfactants (< 5%). A spray glass cleaner may be used.

### 6.1.7. Cleaning of painted parts

Do not clean the painted parts with wet rags when the unit is in operation or hot to prevent thermal shock to the paint which may cause it to detach. Do not use abrasive or aggressive products or materials.

Clean with damp cotton or paper towels.



The silicon paints used on MCZ products possess technical characteristics that make them resistant to very high temperatures.

There is however a physical limit (380°-400°) beyond which the paint begins to fade or (over 450°) to vitrify; it may then flake and detach from the steel surface.

If this happens, it means that temperatures have been reached that are far above those at which the unit should operate properly.

## 6.2. CLEANING TO BE PERFORMED BY SPECIALIZED TECHNICIAN

### 6.2.1. Cleaning the heat exchanger and the pipe unit

Halfway through the winter, but **especially in the spring**, you will need to clean the compartment where discharge smoke passes.

This cleaning must be done in order to remove all combustion residues before time and humidity let them harden and make them difficult to remove.

#### 6.2.1.1. *CLEANING THE EXCHANGER AND PIPE UNIT (EGO/STAR)*

##### **CLEANING THE UPPER COMPARTMENT**

When the stove is cold, remove the top, remove the ceramics/ sides as described in section.3.3., loosening the relative fastening screws before removing the drivers "B" and then remove the boiler cover "C". At this point, remove the turbulators "D" and using a rigid rod or a bottle brush, clean the internal pipe unit and the turbulators, removing all of the accumulated ash.

Check the cover gasket and replace it if necessary.



**ATTENTION:** It is advisable to carry out the cleaning of the upper exchanger at the end of the season and possibly by an authorised MCZ technician in order to replace the gasket that is below plug "C". (fig.16).

##### **CLEANING THE LOWER COMPARTMENT**

Remove the ash drawer "G", unscrew the screws and remove the plug "E" and with the nozzle of a vacuum cleaner to remove the soot and ash which has accumulated in the exchanger "H". Also remove the grate "F" and clean it every 2/3 days as explained in chap. 5.1



**ATTENTION:** It is advisable to carry out the cleaning of the lower compartment once a week and in any case according to the fuel consumption.

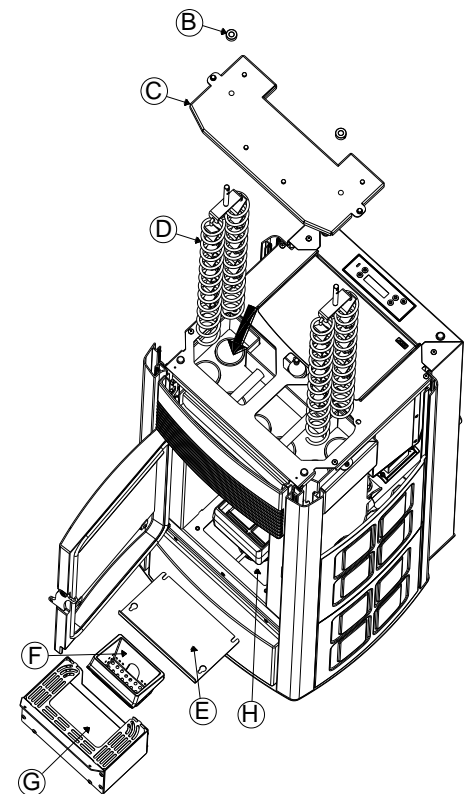

**Figure 16** – Cleaning the pipe unit, turbulator and lower compartment (EGO/STAR)

**6.2.1.2. CLEANING THE EXCHANGER AND PIPE UNIT (SUITE/MUSA and CLUB):**

**CLEANING THE UPPER COMPARTMENT**

When the stove is cold, remove the top, remove the ceramics/ sides as described in section.3.3., loosening the relative fastening screws before removing the drivers "B" and then remove the boiler cover "C". At this point, remove the turbulators "D" and using a rigid rod or a bottle brush, clean the internal pipe unit and the turbulators, removing all of the accumulated ash.

Check the cover gasket and replace it if necessary



**ATTENTION:** It is advisable to carry out the cleaning of the upper exchanger at the end of the season and possibly by an authorised MCZ technician in order to replace the gasket that is below plug "C". (fig.16a).

**CLEANING THE LOWER COMPARTMENT**

Remove the ash drawer "G", empty it and using the nozzle of a vacuum cleaner remove any ash and soot that may have built up under the drawer "G". Also remove the grate "F" and clean it every 2/3 days as explained in chap. 5.1.

Remove the drawer "E", empty it and using the nozzle of a vacuum cleaner remove any ash that may have built up in the housing of the drawer "E".



**ATTENTION:** It is advisable to carry out the cleaning of the lower compartment "E" once a week and in any case according to the fuel consumption.

Check the seal of the ceramic fibre gaskets on the plug and replace it if necessary.

Check the seal of the door gasket and replace it if necessary.

At the end of the season it is necessary to clean the compartment under the grate and the heat exchanger inside it.

This general cleaning should be carried out at the end of the season in order to facilitate the general removal of all residues of combustion, without waiting too long, because with time and humidity these residues can become compacted.

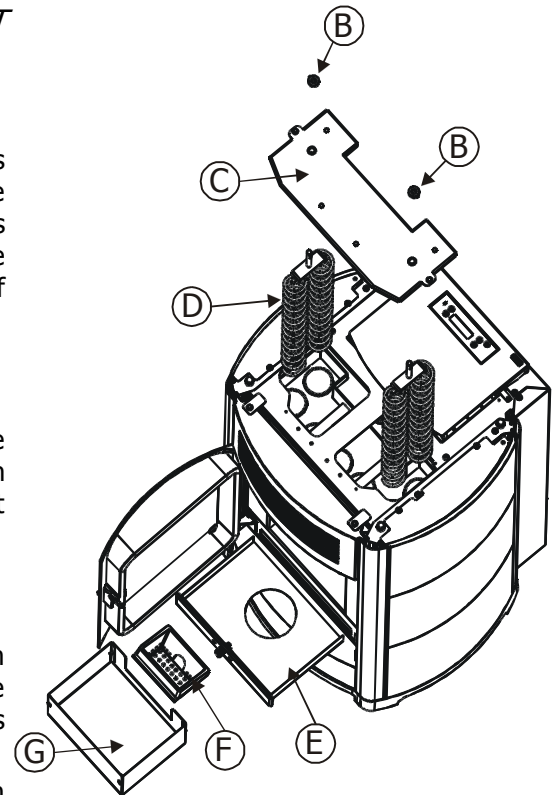

**Figure 16** – Cleaning the pipe unit, turbulator and lower compartment (EGO/STAR)

### 6.2.2. REPLACEMENT OF OVERPRESSURE SILICON DAMPER FOR COMBUSTION CHAMBER

The overpressures silicon damper "G" for combustion chamber (fig. A) shall be replaced with a new one yearly (during the periodical maintenance) in order to keep the overpressure safety system efficient.

For replacement use the following instructions

- remove the top
- remove the first lateral ceramic covering / metal covering (in accordance with the model)
- unscrew the screw-washer-damper-spacer shown in fig. A/C (operate same way on both sides)

Install the new kit as follows:

- Prepare the screw-washer-damper-spacer aligned as shown in fig.C and screw them in the structure.

screw it completely

Check now the proper compression of dampers, using the gauge included in the kit:

- lay the gauge on the lid (fig.B); the gauge has to lay completely, while the head of the screw has to be in contact with the gauge. If it's not the case, register the screw accordingly.

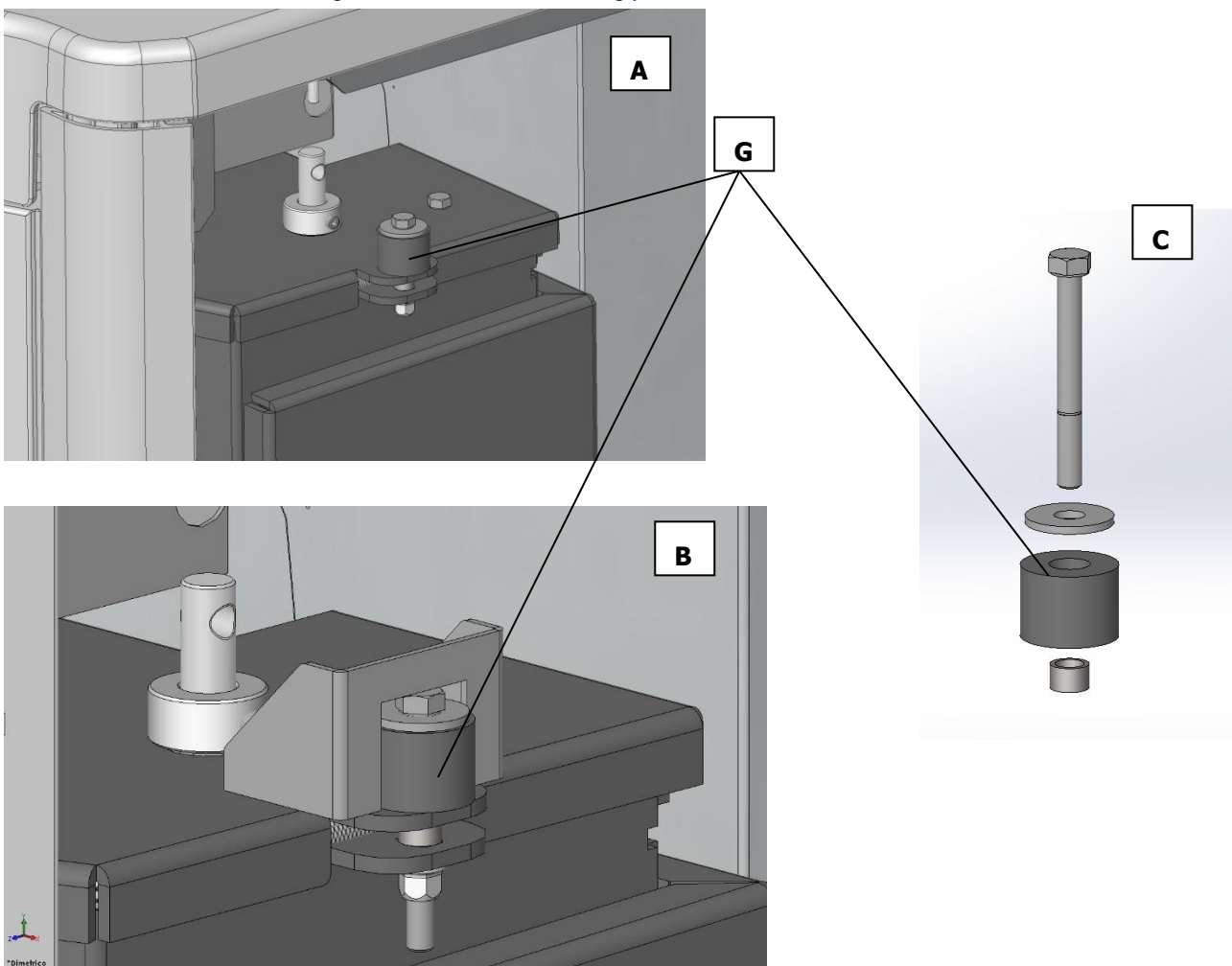

### 6.2.3. Shutting the stove down (end of season)

In the period when the stove is out of use it must be disconnected from the electricity mains. For greater safety, especially if there are children around, we recommend removing the power cable from the rear of the stove. (Figure 17)

Before placing the stove in storage, you should remove all pellets from the hopper with a vacuum cleaner with a long extension. If the fuel is left in the hopper, it may get damp, stick together, and be difficult to light at the beginning of the next season

If the stove is removed from its place of installation it **MUST be placed in a location that is protected from atmospheric agents.**



**Figure 17** – Disconnect the stove from the electrical mains

If pressing the main switch (located on the back of the stove) does not make the control panel display light up, it could mean that the service fuse needs replacing.



**ATTENTION!**  
**Disconnect the electrical cable.**

On the rear of the stove there is a fuse holding compartment which is located underneath the supply socket. With a screwdriver open the cover of the fuse holding compartment, and replace the fuse if necessary (3.15 AT delayed type). Figure 18

Plug the unit back in and press the main switch.

If the problem persists or occurs again, contact your MCZ retailer.

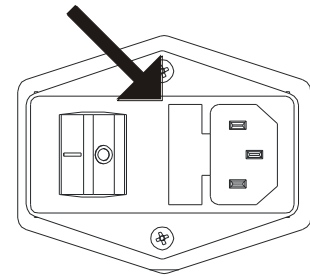

**Figure 18** – Switch with fuse box

### 6.3. CHECK OF INTERNAL COMPONENTS



**ATTENTION!**  
**The check of the internal electromechanical components must be carried out only by qualified personnel with technical knowledge of electricity and combustion. If necessary, contact authorized MCZ retailers.**

We recommend that an annual maintenance service is carried out, preferably under a programmed service contract. The essential part of this service is a visual and functional check on the following components:

- Reduction motor
- Smoke expulsion fan
- Smoke sensor
- Heat-exchanger fan
- Ignition sparkplug
- Resettable pellet thermostat
- Room temperature sensor
- Motherboard / service card
- Fuses protecting panel - motherboard - services card
- Wiring

The following is a summary of the checks and/or maintenance tasks which are indispensable for the correct operation of the stove.

<b>Parts / interval</b>	<b>Every day</b>	<b>Every 2-3 days</b>	<b>Every 60-90 days</b>	<b>Every 1 year</b>
Grate	●			
Ash drawer	●			
Glass		●		
Lower compartment			●	
Complete exchanger			●	
Smoke duct			●	
Ash drawer door gasket				●
Internal parts				●
Flue pipe				●
Circulation pump				●
Plate heat exchanger				●
Plumbing components				●
Electro-mechanical components				●
Overpressure silicon damper for combustion chamber				●

## 7. PROBLEMS / CAUSES / SOLUTIONS



**ATTENTION:**

**All repairs must be carried out exclusively by a specialised technician, with the stove completely cold and the electric plug pulled out.**

PROBLEM	POSSIBLE CAUSES	REMEDY
<b>Pellets not being fed into the combustion chamber.</b>	<ol style="list-style-type: none"> <li>1. Pellet hopper empty.</li> <li>2. Feeder screw blocked by sawdust.</li> <li>3. Reduction motor defective.</li> <li>4. Defective electronic board.</li> </ol>	<ol style="list-style-type: none"> <li>1. Refill pellet hopper.</li> <li>2. Empty the hopper and manually free the feeder screw of sawdust.</li> <li><b>3. Replace reduction motor.</b></li> <li><b>4. Replace electronic board.</b></li> </ol>
<b>The fire goes out or the stove stops automatically.</b>	<ol style="list-style-type: none"> <li>1. Pellet hopper empty.</li> <li>2. Pellets not being fed in.</li> <li>3. Intervention of pellet temperature sensor.</li> <li>4. Door not closed properly or gaskets worn.</li> <li>5. Unsuitable pellets.</li> <li>6. Low pellet feed rate.</li> <li>7. Combustion chamber dirty.</li> <li>8. Smoke outlet obstructed.</li> <li>9. Smoke extraction motor failed.</li> </ol>	<ol style="list-style-type: none"> <li>1. Refill pellet hopper.</li> <li>2. See previous problem..</li> <li>3. Let the stove cool down completely, reset the thermostat till lockout ceases, relight stove; if problem persists, contact technical assistance.</li> <li><b>4. Close the door or replace the gaskets with original spare parts.</b></li> <li>5. Change to a type of pellet recommended by the manufacturer.</li> <li><b>6. Have the fuel feed rate checked by technical service.</b></li> <li>7. Clean the combustion chamber, following instructions in the manual.</li> <li>8. Clean the smoke duct.</li> <li><b>9. Check the motor and replace if necessary.</b></li> </ol>
<b>The stove runs for a few minutes and then goes out.</b>	<ol style="list-style-type: none"> <li>1. Lighting cycle not completed.</li> <li>2. Temporary failure of electricity supply.</li> <li>3. Smoke duct obstructed.</li> <li>4. Temperature sensors defective or broken.</li> <li>5. Sparkplug failure.</li> </ol>	<ol style="list-style-type: none"> <li>1. Re-run lighting cycle.</li> <li>2. See previous instruction.</li> <li>3. Clean smoke duct.</li> <li><b>4. Check and replace sensors as necessary.</b></li> <li><b>5. Check the plug and replace if necessary.</b></li> </ol>
<b>Pellets build up in grate, door glass gets dirty and flame is weak.</b>	<ol style="list-style-type: none"> <li>1. Insufficient combustion air.</li> <li>2. Pellets damp or unsuitable.</li> <li>3. Smoke extractor motor broken.</li> </ol>	<ol style="list-style-type: none"> <li>1. Check that the room air intake is present and free. Check that the combustion air filter on the pipe Ø 5 cm for air inlet is not obstructed. Clean the grate and check that all the airways are clear. Carry out a general cleaning of the combustion chamber and the smoke duct. Check the state of the door gaskets.</li> <li>2. Change the type of pellet.</li> <li><b>3. Check the motor and replace if necessary.</b></li> </ol>
<b>The smoke extraction motor does not work.</b>	<ol style="list-style-type: none"> <li>1. No electrical supply to the stove.</li> <li>2. The motor is broken.</li> <li>3. Defective electronic board.</li> <li>4. Control panel broken.</li> </ol>	<ol style="list-style-type: none"> <li>1. Check the supply voltage and the protection fuse.</li> <li><b>2. Check the motor and capacitor and replace if necessary.</b></li> <li><b>3. Replace electronic board.</b></li> <li><b>4. Replace the control panel.</b></li> </ol>

PROBLEM	POSSIBLE CAUSES	REMEDY
<b>In the automatic position the stove always runs at full power.</b>	<ol style="list-style-type: none"> <li>1. Room thermostat set to maximum.</li> <li>2. Temperature sensor defective.</li> <li>3. Control panel defective or broken.</li> </ol>	<ol style="list-style-type: none"> <li>1. Reset the thermostat temperature.</li> <li>2. <b>Check the operation of the sensor and replace if necessary.</b></li> <li>3. <b>Check the panel and replace if necessary.</b></li> </ol>
<b>The stove does not run</b>	<ol style="list-style-type: none"> <li>1. Lack of electricity supply.</li> <li>2. Pellet sensor in lockout.</li> <li>3. Fuse blown.</li> </ol>	<ol style="list-style-type: none"> <li>1. Check that the electric socket is plugged in and that the main switch is in position "I".</li> <li>2. Clear lockout by resetting the rear thermostat, <b>replace the thermostat if it happens again.</b></li> <li>3. Replace the fuse.</li> </ol>

### ANOMALIES RELATED TO THE PLUMBING CIRCUIT

PROBLEM	POSSIBLE CAUSES	REMEDY
<b>No increase in temperature with stove in operation</b>	<ol style="list-style-type: none"> <li>1. Incorrect combustion adjustment.</li> <li>2. Boiler / system dirty.</li> <li>3. Insufficient stove power.</li> <li>4. Poor pellet quality</li> </ol>	<ol style="list-style-type: none"> <li>1. Check recipe and parameters.</li> <li>2. Check and clean the boiler.</li> <li>3. Check that the stove is properly sized for the requirements of the system.</li> <li>4. Use MCZ pellets</li> </ol>
<b>Condensation in boiler</b>	<ol style="list-style-type: none"> <li>1. Incorrect temperature setting.</li> <li>2. Insufficient fuel consumption.</li> </ol>	<ol style="list-style-type: none"> <li>1. <i>Set the stove to a higher temperature.</i></li> <li>2. <i>Check the recipe and/or technical parameters.</i></li> </ol>
<b>Radiators cold in winter</b>	<ol style="list-style-type: none"> <li>1. Room thermostat (local or remote) set too low. If remote thermostat, check if it is defective.</li> <li>2. Circulator does not run because blocked.</li> <li>3. Circulator does not run.</li> <li>4. Radiators have air in them</li> </ol>	<ol style="list-style-type: none"> <li>1. <i>Set to higher temperature or replace. (if remote)</i></li> <li>2. <i>Free up the circulator by removing the plug and turning the shaft with a screwdriver.</i></li> <li>3. <i>Check the electrical connections of the circulator; replace if necessary.</i></li> <li>4. <i>Vent the radiators</i></li> </ol>
<b>Hot water is not provided</b>	<ol style="list-style-type: none"> <li>1. Circulator (pump) blocked</li> </ol>	<ol style="list-style-type: none"> <li>1. <i>Free the circulator (pump)</i></li> </ol>



**ATTENTION!**

**The operations *in italics* must be carried out by specialised MCZ personnel.**

**The manufacturer refuses to accept any responsibility and the guarantee lapses if this condition is not respected.**



## 8. ELECTRICAL DIAGRAMS

### 8.1. HEATING-ONLY VERSION

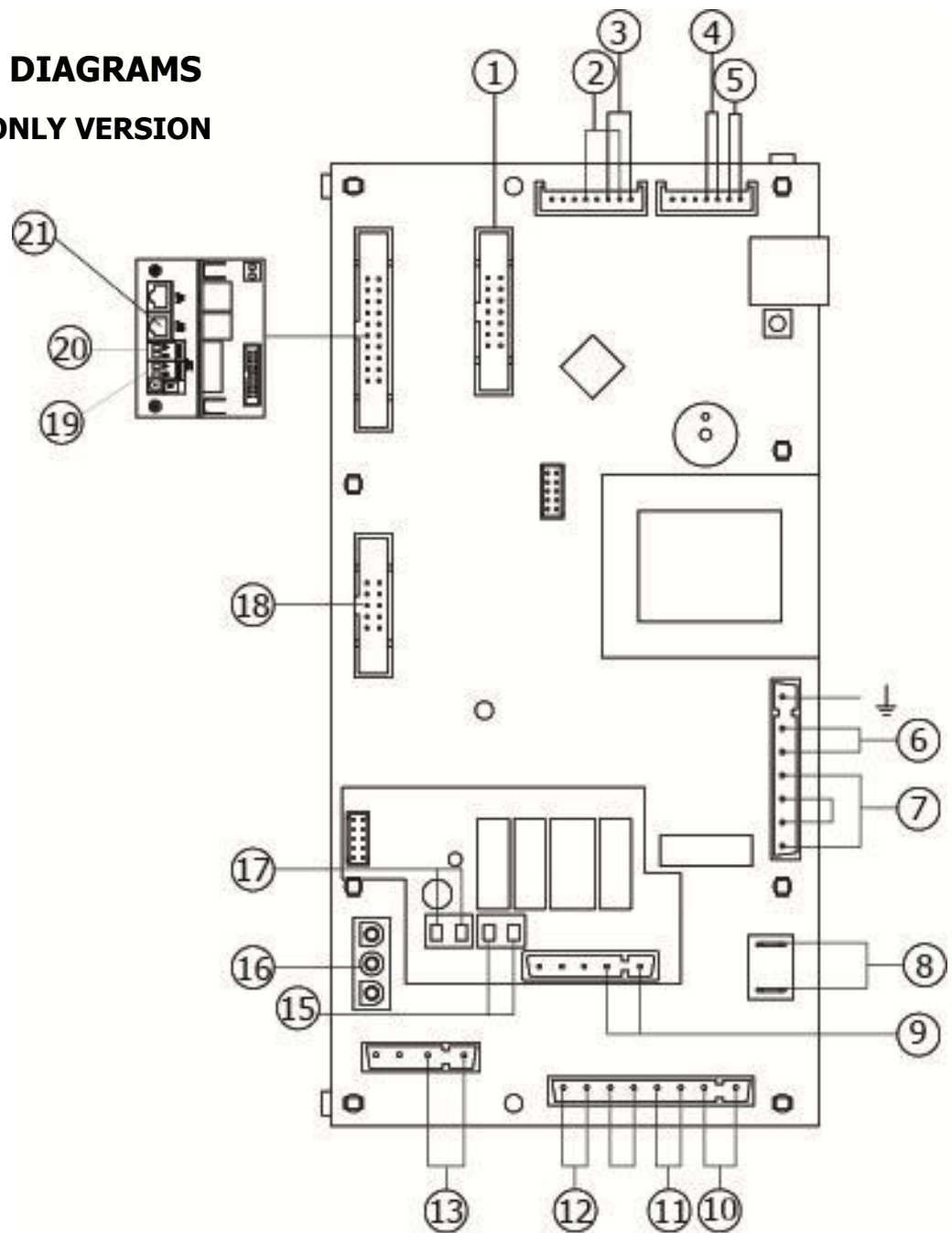
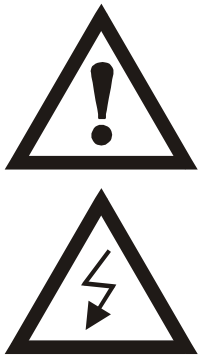

#### MOTHERBOARD WIRING KEY

- |  |   |
|--|---|
| 1. Control panel                       | 11. Gearmotor                                   |
| 2. Flow switch (if there is one)       | 12. Tank temperature overload cut-out           |
| 3. Water temperature probe             | 13. Room fan (if there is one)                  |
| 4. Ambient probe                       | 14. -----                                       |
| 5. Smoke probe                         | 15. Anomaly signal (N.O., max 230V 3A)          |
| 6. Power supply                        | 16. Smoke extractor fan revolutions control     |
| 7. Spark plug                          | 17. External aux signal (N.C., max 230V 3A)     |
| 8. Smoke ejection fan                  | 18. Air flow rate sensor                        |
| 9. Pump                                | 19. Home automation system                      |
| 10. Water temperature overload cut-out | 20. Room thermostat with potential-free contact |
|  | 21. Modem                                       |

**PLEASE NOTE** The electrical wiring of individual components is fitted with prewired connectors with different sizes.

## 8.2. VERSION THAT PRODUCES DHW

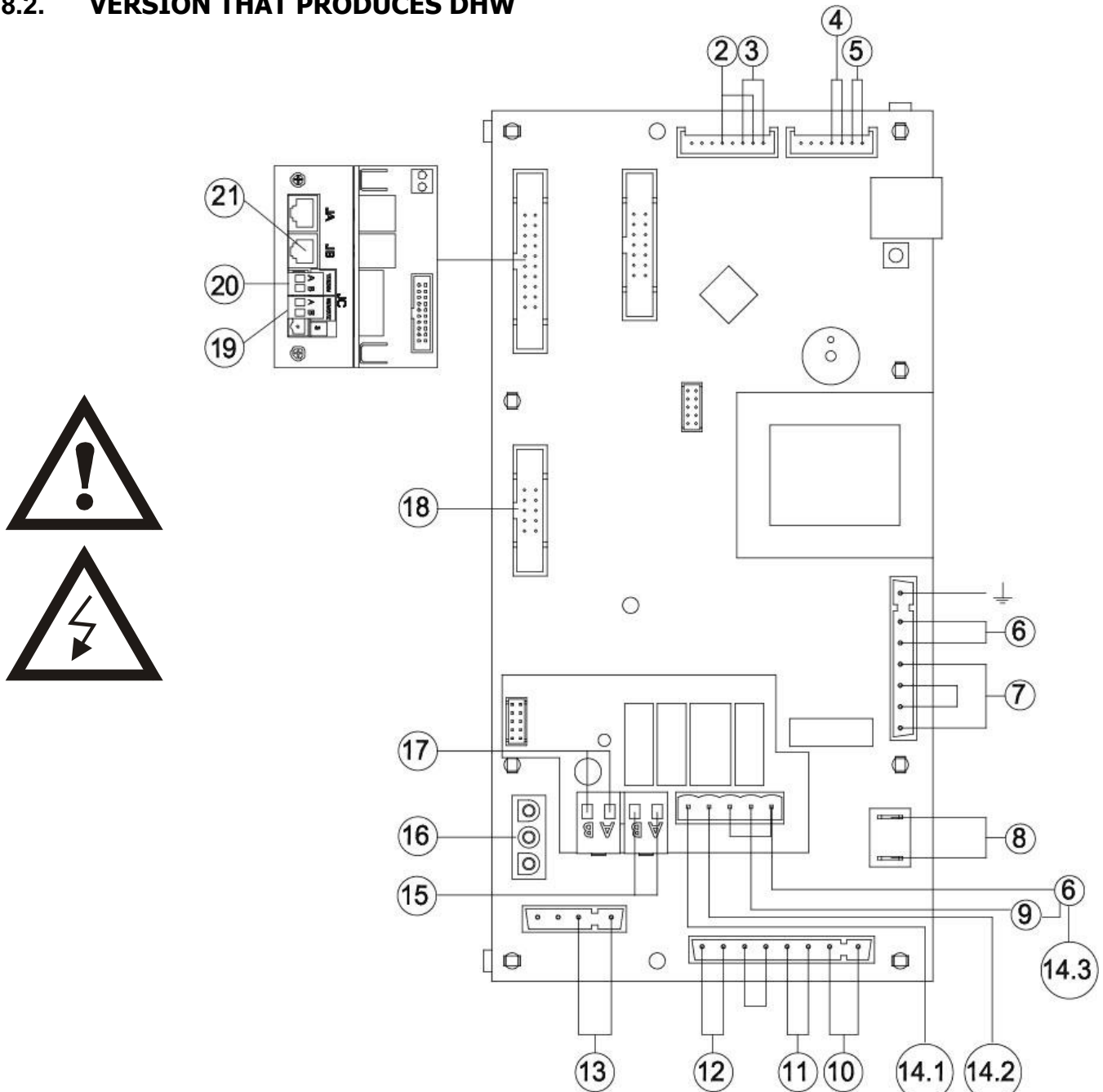

### MOTHERBOARD WIRING KEY

<ol style="list-style-type: none"> <li>1. Control panel</li> <li>2. Flow switch (if there is one)</li> <li>3. Water temperature probe</li> <li>4. Ambient probe</li> <li>5. Smoke probe</li> <li>6. Power supply</li> <li>7. Spark plug</li> <li>8. Smoke ejection fan</li> <li>9. Pump</li> <li>10. Water temperature overload cut-out</li> <li>11. Gearmotor</li> <li>12. Tank temperature overload cut-out</li> <li>13. Room fan (if there is one)</li> </ol>	<ol style="list-style-type: none"> <li>14. -----</li> <li>14.1 3-way DHW boiler</li> <li>14.2 3-way heating</li> <li>14.3 3-way COM.</li> <li>15. Anomaly signal (N.O., max 230V 3A)</li> <li>16. Smoke extractor fan revolutions control</li> <li>17. External aux signal (N.C., max 230V 3A)</li> <li>18. Air flow rate sensor</li> <li>19. Home automation system</li> <li>20. Room thermostat with potential-free contact</li> <li>21. Modem</li> </ol>
--	---

**PLEASE NOTE** The electrical wiring of individual components is fitted with prewired connectors with different sizes.





**MCZ GROUP S.p.A.**

Via La Croce n°2

33074 Vigonovo di Fontanafredda (PN) – ITALY

Telephone: 0434/599599 r.a.

Fax: 0434/599598

Internet: [www.mcz.it](http://www.mcz.it)

e-mail: [mcz@mcz.it](mailto:mcz@mcz.it)